



# AURORA<sup>®</sup> PVM(X) SERIES VERTICAL MULTISTAGE PUMPS



Certified to  
NSF/ANSI 61 & 372

PVM(X) 1  
through  
PVM(X)150  
316 SST  
Models Only

# A LEADER IN WATER TECHNOLOGY

Pentair is one of the world's leading companies in the planning and manufacture of innovative products and systems suitable in any situation requiring the treatment, transportation and storage of water. The activity and success of Pentair is based on values such as constant improvement, the continuous development of new products, high-performance, competence, business ethics and market leadership. Pentair's employees share personal values such as accountability, deep respect for people and the environment and a candid and practical work style. Strong customer relationships and high quality standards allow Pentair to rank amongst the leading producers of technology and instruments for water treatment.



## FLOW TECHNOLOGIES

Vertical and horizontal centrifugal pumps; submersible pumps for domestic, commercial, agricultural and industrial use; pumps for the drainage of clear and wastewaters; pressure booster units and fire-fighting systems.



## FILTRATION

Industrial, residential and commercial filtration systems; filter cartridges, components for the filtration of drinking water, pumps for mobile homes and boats and pumps and accessories for applications in industry and the catering service.

## SAFE, CLEAN WATER

Providing clean, safe water to an ever-growing portion of the population is the Mission of Pentair: a valid organization is engaged to serve our customers in an efficient manner through production plants located in every corner of the world and specialized sales and marketing networks.



## WATER TREATMENT

Residential, commercial and industrial water conditioning control valves; fibre-glass wound expansion tanks and vessels; water storage tanks.



## POOL AND SPA

A complete range of pool/spa equipment and accessories: filters, pumps, heating and lighting systems and cleaning accessories; dosing and control systems and products and accessories for fountains and ponds.

# PVM(X) VERTICAL MULTISTAGE CENTRIFUGAL PUMPS

HIGH HYDRAULIC EFFICIENCY, MOTOR DESIGNED TO NEMA STANDARDS

---

The PVM and PVMX are vertical multistage pumps with flanged/NPT or grooved connections.

Stage construction with stainless steel impellers, chambers and pressure casing. Pump shaft and motor shaft of the NEMA-standard motor are directly close coupled.

All pumps are equipped with a cartridge type mechanical seal for easy maintenance.

PVM and PVMX pumps have different pump sizes and various numbers of stages to provide the flow and the pressure required.

## APPLICATIONS

---

- Water supply
- Pressure boosting systems
- Water treatment/filtration
- Irrigation
- High pressure washes
- Liquid transfer
- Firefighting systems
- Boiler feed



# PVM(X)

## VERTICAL MULTISTAGE CENTRIFUGAL PUMPS

### IDENTIFICATION CODE

The attached Aurora® PVM multistage pump pages include a new pump nomenclature and set of part numbers which will allow you to order pumps with a pre-configured set of product features.

**Materials: Cast Iron**  
**Motor Phase: 1 Ph**

#### Part Number Nomenclature

**Example: PVM X - 3 - 102**

- PVM** – Aurora Vertical Multistage
- X** – Material of Construction (wetted surfaces)
  - ALL 316 SST construction

1	– Flow Series		BEP (gpm)			Flow Series		BEP (gpm)			Flow Series		BEP (gpm)	
	1	10.4	15	97		64	325							
	3	16	20	106		90	360							
	5	30	33	145		120	560							
	10	55	45	205		150	760							

- 3** – Staging  
 First digit or digits (example '3') designates the number of stages that the pump is built with. For pumps built with multiple impeller sizes, they are designated by the number of total impellers followed by the number of stages with the smaller impeller size. Example: PVM33-5-2 has 5 impellers, 2 of which are the smaller impeller size.

- 102** – Configurable options  
 Last three (3) digits describe the required pump connections, elastomers and motor enclosure and voltage requirements. In this example from page 3 (illustrated in the chart below), '102' represents: flange, EPDM elastomers, TEFC 115/280V 1 ph motor. Please consult the price sheet for details.

Connection			Flange							
Elastomer			EPDM				Viton			
			Pump End ONLY	ODP	TEFC	TEFC Pr. Eff.	Pump End ONLY	ODP	TEFC	TEFC Pr. Eff.
<b>Series</b>	<b>Stages</b>	<b>HP</b>	-100	-101	-102		-300	-301	-302	
PVMX1-2	2	0.50	\$860		\$1,301		\$901		\$1,342	
PVMX1-3	3	0.50	902	Not Available	1,343	Not Available	943	Not Available	1,384	Not Available
PVMX1-4	4	0.50	973		1,414		1,014		1,455	
PVMX1-5	5	0.75	1,042		1,549		1,083		1,590	

### PERFORMANCE RANGE

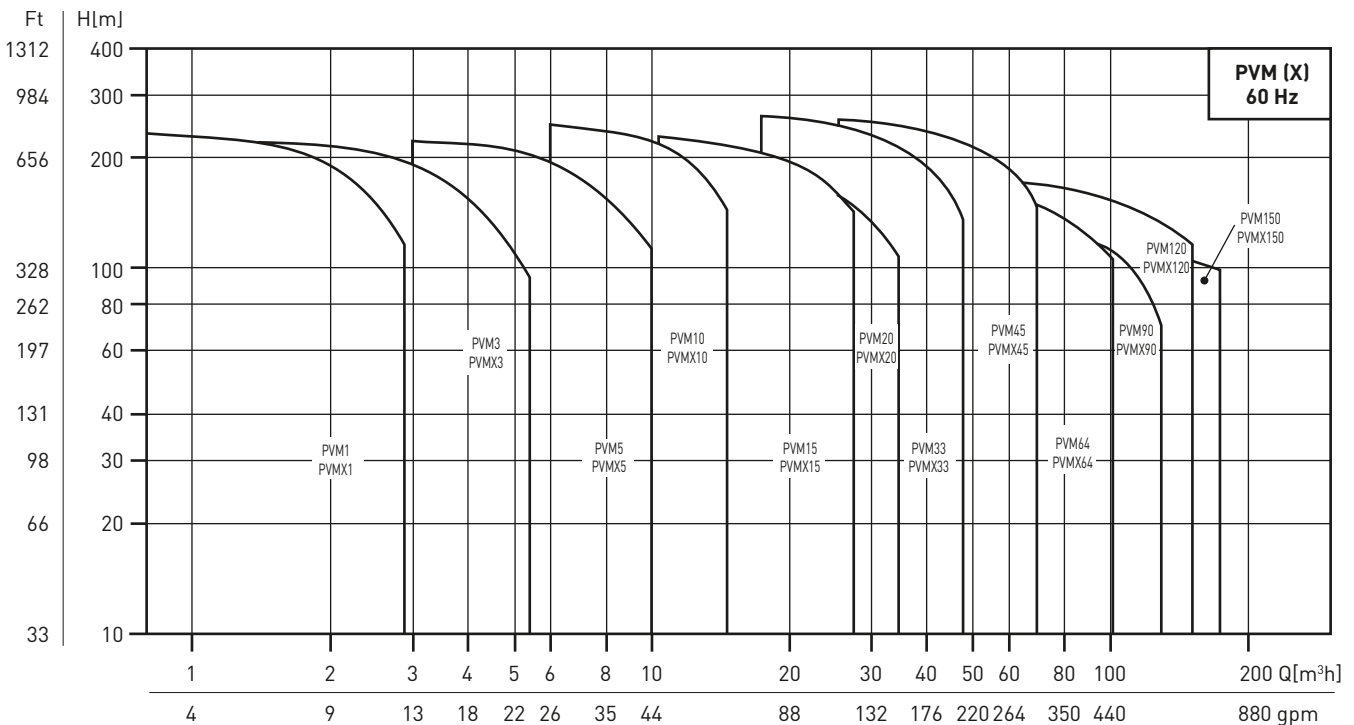

# PVM(X)

## VERTICAL MULTISTAGE CENTRIFUGAL PUMPS

### MOTOR

- TEFC motor with enclosed stator and external ventilation
- Main dimensions are in accordance with NEMA standards
- Class B or better insulation
- Maximum environmental temperature 40°C
- Speed of rotation 3500 rpm

Motor Type: 2-pole						
HP	Phase	Voltage	Frame Size	Phase	Voltage	Frame Size
0.5	1	115V/208-230V	56C	3	208-230V/460V	56C
0.75	1	115V/208-230V	56C	3	208-230V/460V	56C
1	1	115V/208-230V	56C	3	208-230V/460V	56C
1.5	1	115V/208-230V	56C	3	208-230V/460V	56C
2	1	115V/208-230V	56C	3	208-230V/460V	56C
3	1	115V/208-230V	182TC	3	208-230V/460V	182TC
5	1	208-230V	213TC	3	208-230V/460V	184TC
7.5	1	208-230V	213TC	3	208-230V/460V	213TC
10	1	208-230V	215TC	3	208-230V/460V	215TC
15	N/A	N/A	N/A	3	208-230V/460V	254TC
20	N/A	N/A	N/A	3	230V/460V	254TC
25	N/A	N/A	N/A	3	230V/460V	284TSC
30	N/A	N/A	N/A	3	230V/460V	284TSC
40	N/A	N/A	N/A	3	230V/460V	284TSC
50	N/A	N/A	N/A	3	230V/460V	326TSC (TEFC)
60	N/A	N/A	N/A	3	230V/460V	364TSC (TEFC)
75	N/A	N/A	N/A	3	230V/460V	365TSC (TEFC)
100	N/A	N/A	N/A	3	230V/460V	405TSC (TEFC)

# PVM(X)

## VERTICAL MULTISTAGE CENTRIFUGAL PUMPS

### PRODUCT DATA

60Hz	PVM(X)					
	1	3	5	10	15	20
Nominal Flow – US gpm	10.4	16	30	55	97	106
Flow Range – US gpm	1-20	1.5-30	3-60	5.5-95	9.5-150	11-170
Max. Pressure – psi (ft)	360 (832)	360 (832)	360 (832)	360 (832)	360 (832)	360 (832)
Fluid Temperature – °F (°C)	5°F to + 250°F (-15°C to + 120°C)					
Motor Power – hp	0.5-3	0.5-5	0.75-7.5	0.75-15	2-25	3-25
<b>Version</b>						
PVM: Cast Iron EN 1.4301/AISI 304"	•	•	•	•	•	•
PVMX: Stainless Steel EN 1.4401/AISI 316"	•	•	•	•	•	•
<b>Motor</b>						
Main Connection	Usable at 208V 208-230V/460 (0.5-15 hp); 230V/460V (20-100 hp)					
Insulation class	B					
Ambient temperature	40°C					
<b>PVM Pipe Connection</b>						
Flange/NPT	1-1/4" ANSI 250#/1-1/4" NPT Female	1-1/4" ANSI 250#/1-1/4" NPT Female	1-1/4" ANSI 250#/1-1/4" NPT Female	2" ANSI 250#/2" NPT Female	2" ANSI 250#/2" NPT Female	2" ANSI 250#/2" NPT Female
<b>PVMX Pipe Connection</b>						
Flange	1-1/4 ANSI 250#	1-1/4 ANSI 250#	1-1/4 ANSI 250#	2" ANSI 250#	2" ANSI 250#	2" ANSI 250#
Grooved connection	R¼ DN32	R¼ DN32	R¼ DN32	R2 DN50	R2 DN50	R2 DN50
<b>Mechanical Seals</b>						
SiC/SiC	Standard					
<b>Seals</b>						
EPDM	Standard					
Viton	Optional					

# PVM(X)

## VERTICAL MULTISTAGE CENTRIFUGAL PUMPS

### PRODUCT DATA

60Hz	PVM(X)					
	33	45	64	90	120	150
Nominal Flow – US gpm	145	205	345	385	570	760
Flow Range – US gpm	35-225	40-350	45-440	45-550	70-700	100-850
Max. Pressure – psi (ft)	435 (1005)	435 (1005)	435 (1005)	435 (1005)	435 (1005)	435 (1005)
Fluid Temperature – °F (°C)	5°F to + 250°F (-15°C to + 120°C)					
Motor Power – hp	5-40	7.5-60	10-60	15-60	20-100	25-100
<b>Version</b>						
PVM: Cast Iron EN 1.4301/AISI 304"	•	•	•	•	•	•
PVMX: Stainless Steel EN 1.4401/AISI 316"	•	•	•	•	•	•
<b>Motor</b>						
Main Connection	Usable at 208V 208-230V/460 (0.5-15 hp); 230V/460V (20-100 hp)					
Insulation class	B					
Ambient temperature	40°C					
<b>PVM Pipe Connection</b>						
Flange	2-1/2" ANSI 250#	3" ANSI 250#	4" ANSI 250#	4" ANSI 250#	5" ANSI 250#	5" ANSI 250#
<b>PVMX Pipe Connection</b>						
Flange	2-1/2" ANSI 250#	3" ANSI 250#	4" ANSI 250#	4" ANSI 250#	5" ANSI 250#	5" ANSI 250#
Grooved connection	N/A	N/A	N/A	N/A	N/A	N/A
<b>Mechanical Seals</b>						
SiC/SiC	Standard					
<b>Seals</b>						
EPDM	Standard					
Viton	Optional					

# PVM(X)

## VERTICAL MULTISTAGE CENTRIFUGAL PUMPS

### PUMP CONSTRUCTION

POS.	NAME	MATERIAL	PVM 1, 3, 5, 10, 15, 20	PVMX 1, 3, 5, 10, 15, 20
36	Pump head	Cast iron	EN-GJL-200 ; ASTM 25B	EN-GJS-450-10 ; ASTM 65-45-12
56	Pump head cover	Stainless steel	-	1.4401 ; AISI 316
18	Impeller	Stainless steel	1.4301 ; AISI 304	1.4401 ; AISI 316
37	Shaft	Stainless steel	1.4057 ; AISI 431	1.4401 ; AISI 316
48	Outer sleeve	Stainless steel	1.4301 ; AISI 304	1.4401 ; AISI 316
82	O-ring for outer sleeve	Epdm or viton	-	-
12	Chamber	Stainless steel	1.4301 ; AISI 304	1.4401 ; AISI 316
24	Neck Ring	PTFE	-	-
59	Base	Cast iron	EN-GJL-200 ; ASTM 25B	-
		Stainless steel	-	1.4401 ; AISI 316
62	Base plate	Cast iron	-	EN-GJL-200 ; ASTM 25B
44	Coupling	Fe-Cu-C	SINT C11 ; MPIF FC0525	SINT C11 ; MPIF FC0525
57	Mechanical seal	Cartridge type	Sic/Sic Faces with AISI 304 & 316 components	

**PVM – 1, 3, 5, 10, 15, 20**

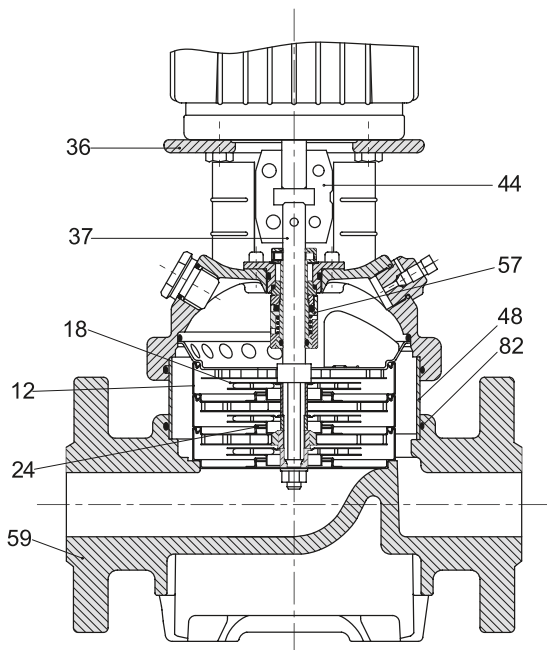

**PVMX – 1, 3, 5, 10, 15, 20**

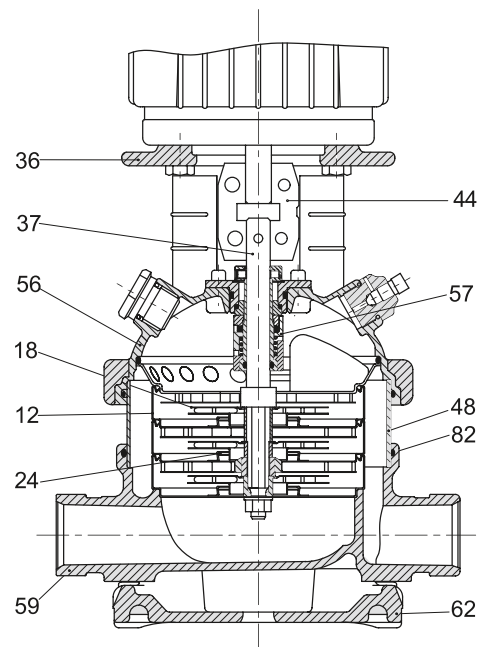

# PVM(X)

## VERTICAL MULTISTAGE CENTRIFUGAL PUMPS

### PUMP CONSTRUCTION

POS.	NAME	MATERIAL	PVM 33, 45, 64, 90	PVMX 33, 45, 64, 90
36	Pump head	Cast iron	EN-GJL-250 ; ASTM 35B	-
		Stainless steel	-	1.4401 ; AISI 316
53	Motor bracket	Cast iron	EN-GJL-250 ; ASTM 35B	EN-GJL-250 ; ASTM 35B
18	Impeller	Stainless steel	1.4301 ; AISI 304	1.4401 ; AISI 316
37	Shaft	Stainless steel	1.4057 ; AISI 431	1.4401 ; AISI 316
48	Outer sleeve	Stainless steel	1.4301 ; AISI 304	1.4401 ; AISI 316
82	O-ring for outer sleeve	EPDM or viton	-	-
12	Chamber	Stainless steel	1.4301 ; AISI 304	1.4401 ; AISI 316
24	Neck ring	Carbon fiber + pob + ptfe	-	-
59	Base	Cast iron	EN-GJL-250 ; ASTM 35B	-
		Stainless steel	-	1.4401 ; AISI 316
62	Base plate	Cast iron	-	EN-GJL-250 ; ASTM 35B
57	Mechanical seal	Cartridge type	-	-
14	Bearing ring	-	Bronze	-
42	Bottom bearing ring	Tungsten carbide/tungsten carbide	Tungsten carbide/Tungsten carbide	

**PVM - 33, 45, 64, 90**

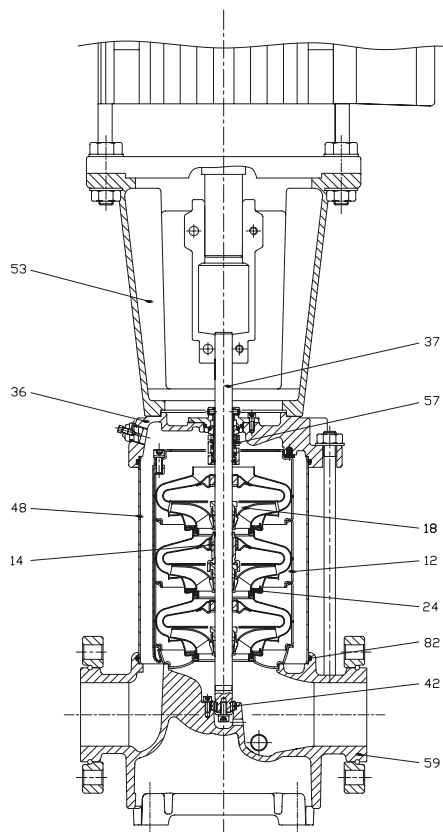

**PVMX - 33, 45, 64, 90**

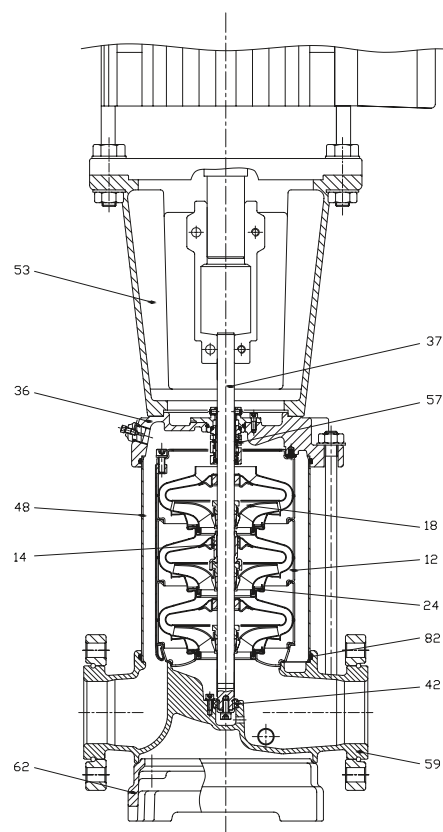

# PVM(X)

## VERTICAL MULTISTAGE CENTRIFUGAL PUMPS

### PUMP CONSTRUCTION

POS.	NAME	MATERIAL	PVM 120, 150	PVMX 120, 150
36	Pump head	Cast iron	EN-GJL-250; ASTM 35B	-
		Stainless steel	-	1.4401; AISI 316
53	Motor bracket (15 hp-60 hp)	Cast iron	EN-GJL-250; ASTM 35B	EN-GJL-250; ASTM 35B
	Motor bracket (75 hp-100 hp)	Cast iron	EN-GJS-450-10; ASTM 65-45-12	EN-GJS-450-10; ASTM 65-45-12
17	Bearing ring	PTFE	PTFE	
18	Impeller	Stainless steel	1.4301; AISI 304	1.4401; AISI 316
37	Shaft	Stainless steel	1.4057; AISI 431	1.4401; AISI 316
48	Outer sleeve	Stainless steel	1.4301; AISI 304	1.4401; AISI 316
82	O-ring for outer sleeve	Epdm or viton	-	-
12	Chamber	Stainless steel	1.4301; AISI 304	1.4401; AISI 316
24	Neck ring	PTFE	-	-
59	Base	Cast iron	EN-GJL-250; ASTM 35B	-
		Stainless steel	-	1.4401; AISI 316
62	Base plate	Cast iron	-	-
62A	Base plate	Cast iron	-	-
57	Mechanical seal	Cartridge type	EN-GJS-450-10; ASTM 65-45-12	
14	Bearing ring	-	Bronze	-
42	Bottom bearing ring	Tungsten carbide/tungsten carbide	-	-

**PVM - 120, 150**

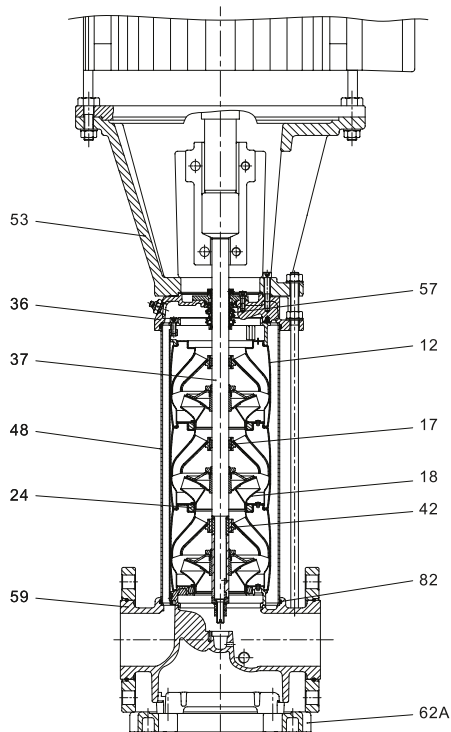

**PVMX - 120, 150**

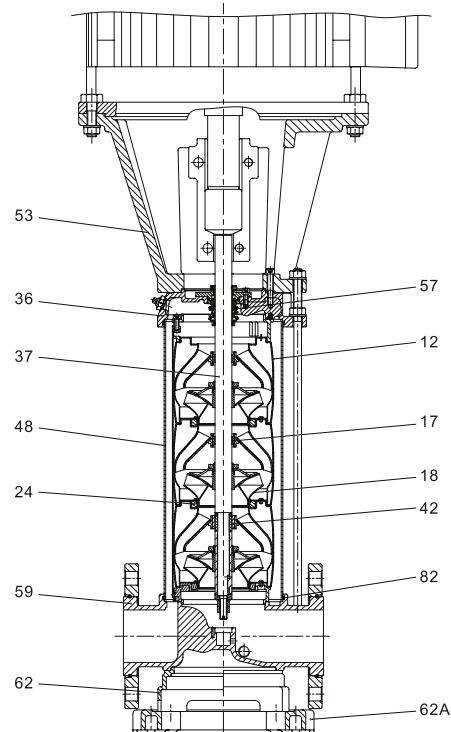

# PVM(X) 1

## VERTICAL MULTISTAGE CENTRIFUGAL PUMPS

### PUMP DIMENSIONS – METRIC

Model Number	Motor HP	Motor Service Factor	Phase	Voltage	Motor Frame	PVM Cast Iron							PVMX Stainless Steel								
						Dimensions in inches						Weight in Lbs		Dimensions in inches						Weight in Lbs	
						A	B	C	D	E	F	Pump End Only	Pump & Motor	A	B	C	D	E	F	Pump End Only	Pump & Motor
PVM(X)1-2	0.5	1.25	1	115V/208-230V	56C	11.0	9.3	6.0	2.1	22.4	6.0	38	59	11.1	9.3	6.0	2.1	22.5	6.0	32	53
PVM(X)1-2	0.5	1.25	3	208-230V/460V	56C	11.0	10.2	6.6	2.1	23.2	6.6	38	73	11.1	10.2	6.6	2.1	23.3	6.6	32	67
PVM(X)1-3	0.5	1.25	1	115V/208-230V	56C	11.0	9.3	6.0	2.1	22.4	6.0	39	60	11.1	9.3	6.0	2.1	22.5	6.0	33	54
PVM(X)1-3	0.5	1.25	3	208-230V/460V	56C	11.0	10.2	6.6	2.1	23.2	6.6	39	74	11.1	10.2	6.6	2.1	23.3	6.6	33	68
PVM(X)1-4	0.5	1.25	1	115V/208-230V	56C	11.7	9.3	6.0	2.1	23.1	6.0	40	61	11.8	9.3	6.0	2.1	23.2	6.0	35	56
PVM(X)1-4	0.5	1.25	3	208-230V/460V	56C	11.7	10.2	6.6	2.1	23.9	6.6	40	75	11.8	10.2	6.6	2.1	24.0	6.6	35	70
PVM(X)1-5	0.5	1.25	1	115V/208-230V	56C	12.4	9.3	6.0	2.1	23.8	6.0	42	63	12.5	9.3	6.0	2.1	23.9	6.0	36	57
PVM(X)1-5	0.5	1.25	3	208-230V/460V	56C	12.4	10.2	6.6	2.1	24.6	6.6	42	77	12.5	10.2	6.6	2.1	24.7	6.6	36	71
PVM(X)1-6	0.75	1.25	1	115V/208-230V	56C	13.1	9.9	6.0	2.1	25.1	6.0	43	72	13.2	9.9	6.0	2.1	25.2	6.0	37	66
PVM(X)1-6	0.75	1.25	3	208-230V/460V	56C	13.1	10.2	6.6	2.1	25.3	6.6	43	73	13.2	10.2	6.6	2.1	25.4	6.6	37	67
PVM(X)1-7	0.75	1.25	1	115V/208-230V	56C	14.1	9.9	6.0	2.1	26.1	6.0	44	73	14.2	9.9	6.0	2.1	26.2	6.0	39	68
PVM(X)1-7	0.75	1.25	3	208-230V/460V	56C	14.1	10.2	6.6	2.1	26.3	6.6	44	74	14.2	10.2	6.6	2.1	26.4	6.6	39	69
PVM(X)1-8	1	1.25	1	115V/208-230V	56C	14.8	10.2	6.6	2.1	27.0	6.6	46	81	14.9	10.2	6.6	2.1	27.1	6.6	40	75
PVM(X)1-8	1	1.25	3	208-230V/460V	56C	14.8	10.4	7.2	2.1	27.3	7.2	46	99	14.9	10.4	7.2	2.1	27.4	7.2	40	93
PVM(X)1-9	1	1.25	1	115V/208-230V	56C	15.5	10.2	6.6	2.1	27.7	6.6	47	82	15.6	10.2	6.6	2.1	27.8	6.6	41	76
PVM(X)1-9	1	1.25	3	208-230V/460V	56C	15.5	10.4	7.2	2.1	28.0	7.2	47	100	15.6	10.4	7.2	2.1	28.1	7.2	41	94
PVM(X)1-10	1.5	1.15	1	115V/208-230V	56C	16.2	11.2	7.2	2.1	29.4	7.2	48	94	16.3	11.2	7.2	2.1	29.5	7.2	42	88
PVM(X)1-10	1.5	1.15	3	208-230V/460V	56C	16.2	11.2	7.2	2.1	29.4	7.2	48	90	16.3	11.2	7.2	2.1	29.5	7.2	42	84
PVM(X)1-11	1.5	1.15	1	115V/208-230V	56C	16.9	11.2	7.2	2.1	30.1	7.2	49	95	17.0	11.2	7.2	2.1	30.2	7.2	44	90
PVM(X)1-11	1.5	1.15	3	208-230V/460V	56C	16.9	11.2	7.2	2.1	30.1	7.2	49	91	17.0	11.2	7.2	2.1	30.2	7.2	44	86
PVM(X)1-12	1.5	1.15	1	115V/208-230V	56C	17.6	11.2	7.2	2.1	30.8	7.2	51	97	17.7	11.2	7.2	2.1	30.9	7.2	45	91
PVM(X)1-12	1.5	1.15	3	208-230V/460V	56C	17.6	11.2	7.2	2.1	30.8	7.2	51	93	17.7	11.2	7.2	2.1	30.9	7.2	45	87
PVM(X)1-13	1.5	1.15	1	115V/208-230V	56C	18.3	11.2	7.2	2.1	31.5	7.2	52	98	18.4	11.2	7.2	2.1	31.6	7.2	46	92
PVM(X)1-13	1.5	1.15	3	208-230V/460V	56C	18.3	11.2	7.2	2.1	31.5	7.2	52	94	18.4	11.2	7.2	2.1	31.6	7.2	46	88
PVM(X)1-15	2	1.15	1	115V/208-230V	56C	20.4	12.1	7.2	2.1	34.5	7.2	55	108	20.5	12.1	7.2	2.1	34.6	7.2	49	102
PVM(X)1-15	2	1.15	3	208-230V/460V	56C	20.4	12.1	7.2	2.1	34.5	7.2	55	104	20.5	12.1	7.2	2.1	34.6	7.2	49	98
PVM(X)1-17	2	1.15	1	115V/208-230V	56C	21.8	12.1	7.2	2.1	35.9	7.2	57	110	21.9	12.1	7.2	2.1	36.0	7.2	52	105
PVM(X)1-17	2	1.15	3	208-230V/460V	56C	21.8	12.1	7.2	2.1	35.9	7.2	57	106	21.9	12.1	7.2	2.1	36.0	7.2	52	101
PVM(X)1-19	3	1.15	1	115V/208-230V	182TC	23.7	15.4	8.9	2.6	41.7	8.9	62	150	23.3	15.4	8.9	2.6	41.3	8.9	56	144
PVM(X)1-19	3	1.15	3	208-230V/460V	182TC	23.7	13.9	8.9	2.6	40.3	8.9	62	130	23.3	13.9	8.9	2.6	39.9	8.9	56	124
PVM(X)1-21	3	1.15	1	115V/208-230V	182TC	25.1	15.4	8.9	2.6	43.1	8.9	64	152	24.7	15.4	8.9	2.6	42.7	8.9	58	146
PVM(X)1-21	3	1.15	3	208-230V/460V	182TC	25.1	13.9	8.9	2.6	41.7	8.9	64	132	24.7	13.9	8.9	2.6	41.3	8.9	58	126
PVM(X)1-23	3	1.15	1	115V/208-230V	182TC	27.3	15.4	8.9	2.6	45.3	8.9	67	155	26.1	15.4	8.9	2.6	44.1	8.9	61	149
PVM(X)1-23	3	1.15	3	208-230V/460V	182TC	27.3	13.9	8.9	2.6	43.9	8.9	67	135	26.1	13.9	8.7	2.6	42.7	8.7	61	129
PVM(X)1-25	3	1.15	1	115V/208-230V	182TC	28.7	15.4	8.9	2.6	46.7	8.9	69	157	27.6	15.4	8.7	2.6	45.6	8.7	64	152
PVM(X)1-25	3	1.15	3	208-230V/460V	182TC	28.7	13.9	8.9	2.6	45.3	8.9	69	137	27.6	13.9	8.7	2.6	44.2	8.7	64	132
PVM(X)1-27	3	1.15	3	208-230V/460V	182TC	29.5	13.9	8.9	2.6	46.1	8.9	72	140	29.2	13.9	8.7	2.6	45.8	8.7	66	134
PVM(X)1-27	3	1.15	1	115V/208-230V	182TC	29.5	15.4	8.9	2.6	47.5	8.9	72	160	29.2	15.4	8.7	2.6	47.2	8.7	66	154

# PVM(X) 1 VERTICAL MULTISTAGE CENTRIFUGAL PUMPS

## PUMP DIMENSIONS - STANDARD

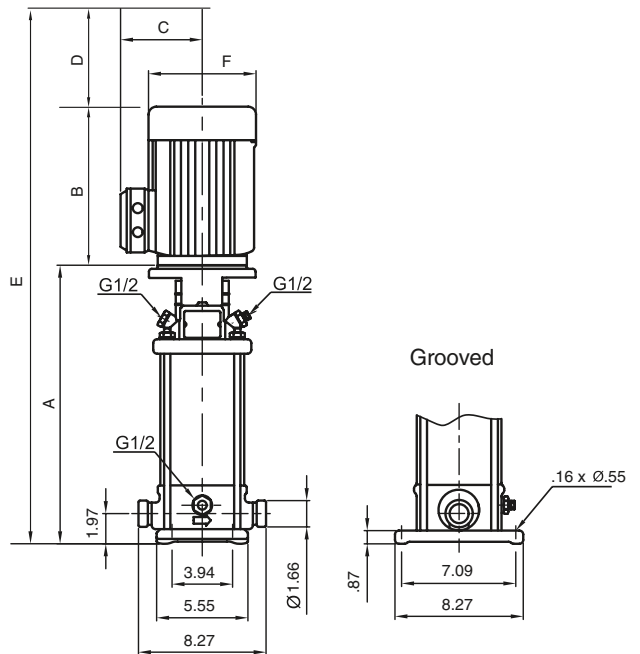
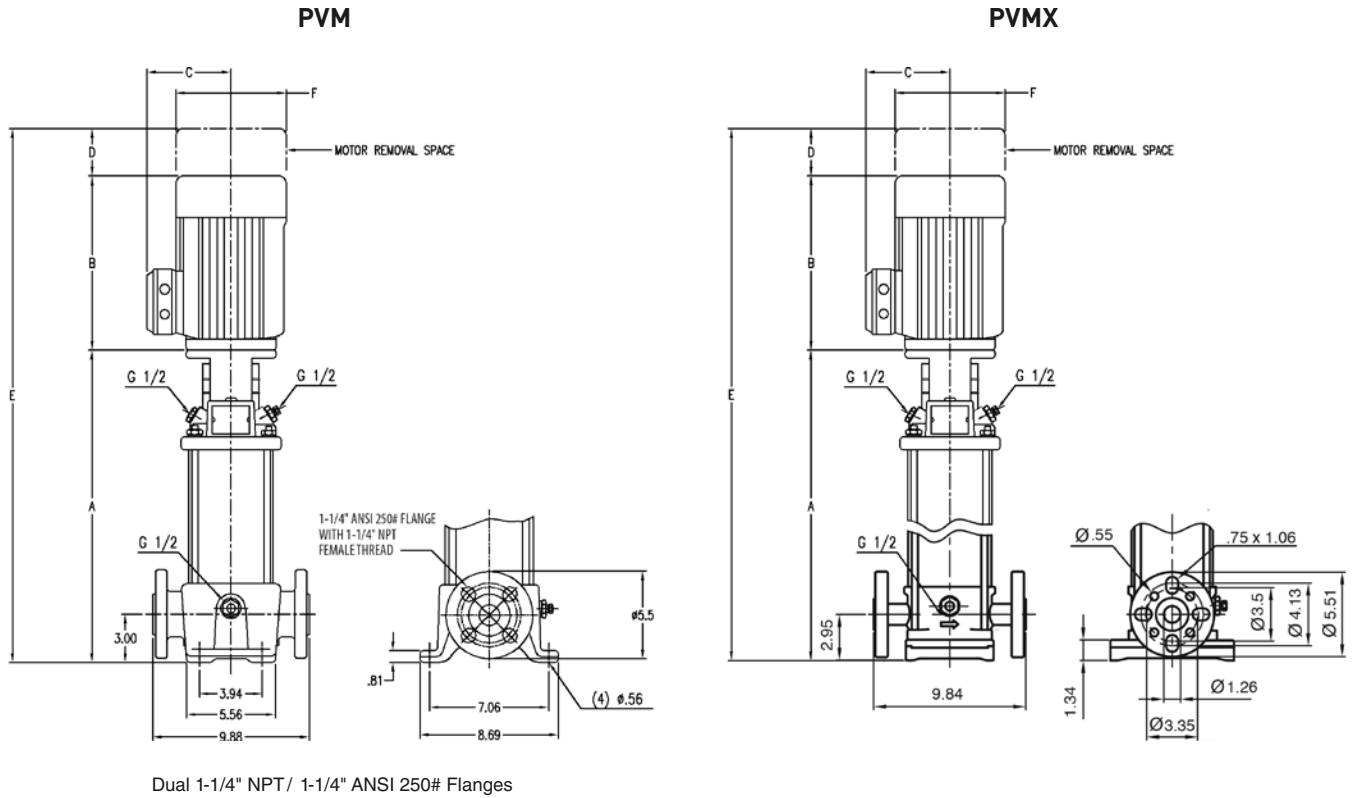

NOTE: G1/2 per ISO-228

# PVM(X) 1

## VERTICAL MULTISTAGE CENTRIFUGAL PUMPS

### PUMP DIMENSIONS – METRIC

Model Number	Motor HP	Motor Service Factor	Phase	Voltage	Motor Frame	PVM Cast Iron								PVMX Stainless Steel							
						Dimensions in mm						Weight in kgs		Dimensions in mm						Weight in kgs	
						A	B	C	D	E	F	Pump End Only	Pump & Motor	A	B	C	D	E	F	Pump End Only	Pump & Motor
PVM(X)1-2	0.5	1.25	1	115V/208-230V	56C	279	236	153	52	568	153	17	27	282	236	153	52	570	153	15	24
PVM(X)1-2	0.5	1.25	3	208-230V/460V	56C	279	258	168	52	590	168	17	33	282	258	168	52	593	168	15	30
PVM(X)1-3	0.5	1.25	1	115V/208-230V	56C	279	236	153	52	568	153	18	27	282	236	153	52	570	153	15	25
PVM(X)1-3	0.5	1.25	3	208-230V/460V	56C	279	258	168	52	590	168	18	34	282	258	168	52	593	168	15	31
PVM(X)1-4	0.5	1.25	1	115V/208-230V	56C	297	236	153	52	586	153	18	28	300	236	153	52	588	153	16	25
PVM(X)1-4	0.5	1.25	3	208-230V/460V	56C	297	258	168	52	608	168	18	34	300	258	168	52	610	168	16	32
PVM(X)1-5	0.5	1.25	1	115V/208-230V	56C	315	236	153	52	603	153	19	28	318	236	153	52	606	153	16	26
PVM(X)1-5	0.5	1.25	3	208-230V/460V	56C	315	258	168	52	626	168	19	35	318	258	168	52	628	168	16	32
PVM(X)1-6	0.75	1.25	1	115V/208-230V	56C	333	252	153	52	637	153	19	33	335	252	153	52	639	153	17	30
PVM(X)1-6	0.75	1.25	3	208-230V/460V	56C	333	258	168	52	643	168	19	33	335	258	168	52	646	168	17	30
PVM(X)1-7	0.75	1.25	1	115V/208-230V	56C	358	252	153	52	662	153	20	33	361	252	153	52	665	153	17	31
PVM(X)1-7	0.75	1.25	3	208-230V/460V	56C	358	258	168	52	669	168	20	34	361	258	168	52	671	168	17	31
PVM(X)1-8	1	1.25	1	115V/208-230V	56C	376	258	168	52	686	168	21	37	378	258	168	52	689	168	18	34
PVM(X)1-8	1	1.25	3	208-230V/460V	56C	376	264	183	52	693	183	21	45	378	264	183	52	695	183	18	42
PVM(X)1-9	1	1.25	1	115V/208-230V	56C	394	258	168	52	704	168	21	37	396	258	168	52	707	168	19	35
PVM(X)1-9	1	1.25	3	208-230V/460V	56C	394	264	183	52	711	183	21	45	396	264	183	52	713	183	19	43
PVM(X)1-10	1.5	1.15	1	115V/208-230V	56C	411	283	182	52	747	182	22	43	414	283	182	52	750	182	19	40
PVM(X)1-10	1.5	1.15	3	208-230V/460V	56C	411	284	183	52	748	183	22	41	414	284	183	52	750	183	19	38
PVM(X)1-11	1.5	1.15	1	115V/208-230V	56C	429	283	182	52	765	182	22	43	432	283	182	52	768	182	20	41
PVM(X)1-11	1.5	1.15	3	208-230V/460V	56C	429	284	183	52	765	183	22	41	432	284	183	52	768	183	20	39
PVM(X)1-12	1.5	1.15	1	115V/208-230V	56C	447	283	182	52	783	182	23	44	450	283	182	52	785	182	20	41
PVM(X)1-12	1.5	1.15	3	208-230V/460V	56C	447	284	183	52	783	183	23	42	450	284	183	52	786	183	20	39
PVM(X)1-13	1.5	1.15	1	115V/208-230V	56C	465	283	182	52	801	182	24	44	467	283	182	52	803	182	21	42
PVM(X)1-13	1.5	1.15	3	208-230V/460V	56C	465	284	183	52	801	183	24	43	467	284	183	52	803	183	21	40
PVM(X)1-15	2	1.15	1	115V/208-230V	56C	518	306	182	52	877	182	25	49	521	306	182	52	879	182	22	46
PVM(X)1-15	2	1.15	3	208-230V/460V	56C	518	306	183	52	877	183	25	47	521	306	183	52	879	183	22	44
PVM(X)1-17	2	1.15	1	115V/208-230V	56C	554	306	182	52	912	182	26	50	556	306	182	52	915	182	23	47
PVM(X)1-17	2	1.15	3	208-230V/460V	56C	554	306	183	52	912	183	26	48	556	306	183	52	915	183	23	46
PVM(X)1-19	3	1.15	1	115V/208-230V	182TC	602	392	225	67	1060	225	28	68	592	392	225	67	1050	225	25	65
PVM(X)1-19	3	1.15	3	208-230V/460V	182TC	602	354	225	67	1022	225	28	59	592	354	225	67	1012	225	25	56
PVM(X)1-21	3	1.15	1	115V/208-230V	182TC	638	392	225	67	1096	225	29	69	627	392	225	67	1086	225	26	66
PVM(X)1-21	3	1.15	3	208-230V/460V	182TC	638	354	225	67	1058	225	29	60	627	354	225	67	1048	225	26	57
PVM(X)1-23	3	1.15	1	115V/208-230V	182TC	693	392	225	67	1152	225	30	70	663	392	225	67	1121	225	28	68
PVM(X)1-23	3	1.15	3	208-230V/460V	182TC	693	354	225	67	1114	225	30	61	663	354	220	67	1083	220	28	59
PVM(X)1-25	3	1.15	1	115V/208-230V	182TC	729	392	225	67	1187	225	31	71	701	392	220	67	1159	220	29	69
PVM(X)1-25	3	1.15	3	208-230V/460V	182TC	729	354	225	67	1149	225	31	62	701	354	220	67	1122	220	29	60
PVM(X)1-27	3	1.15	3	208-230V/460V	182TC	749	354	225	67	1170	225	33	63	742	354	220	67	1162	220	30	61
PVM(X)1-27	3	1.15	1	115V/208-230V	182TC	749	392	225	67	1208	225	33	73	742	392	220	67	1200	220	30	70

# PVM(X) 1 VERTICAL MULTISTAGE CENTRIFUGAL PUMPS

## PUMP DIMENSIONS - METRIC

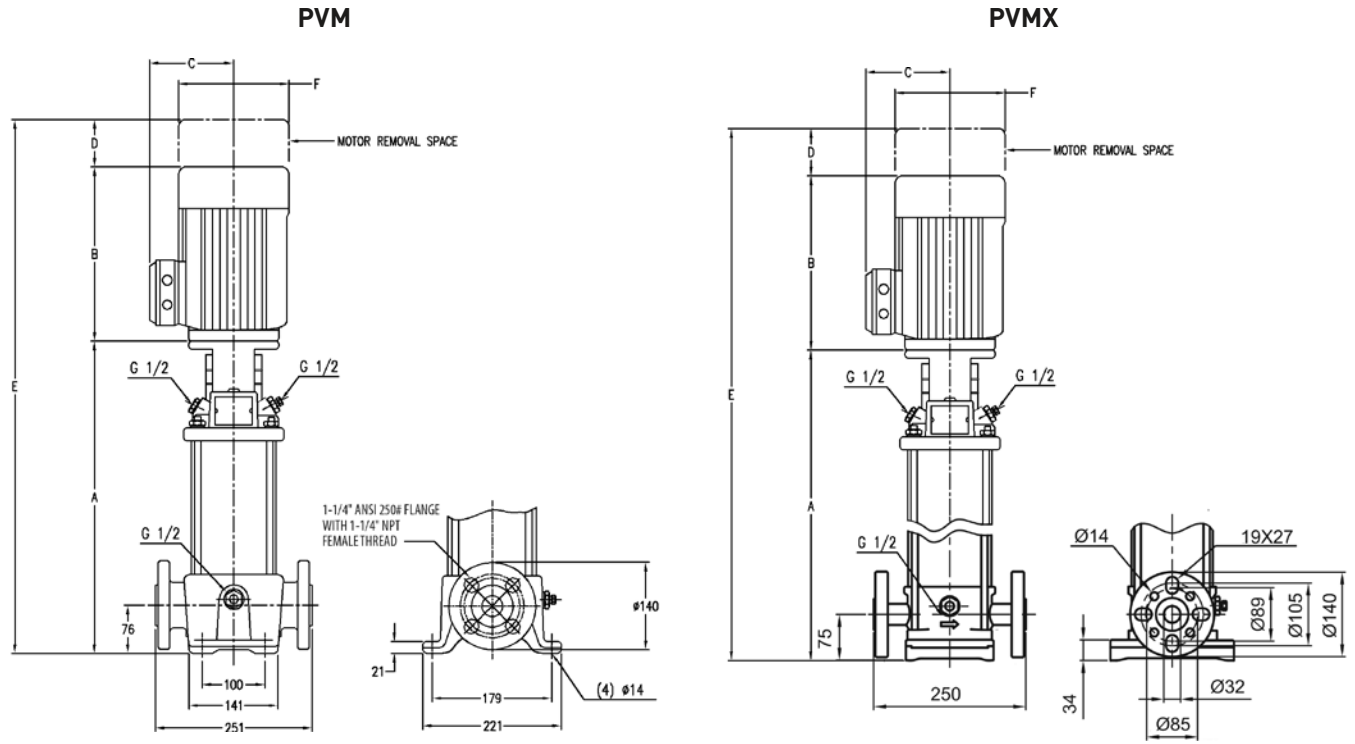

Dual 1-1/4" NPT / 1-1/4" ANSI 250# Flanges

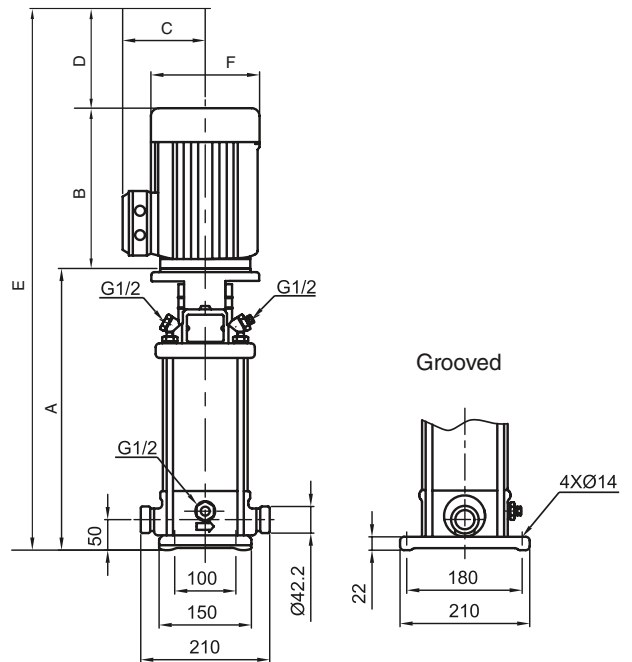

NOTE: G1/2 per ISO-228

# PVM(X) 1

## VERTICAL MULTISTAGE CENTRIFUGAL PUMPS

### HYDRAULIC PERFORMANCE

Curve: PVM(X) 1  
Date: 10/01/14

Nominal rpm: 3500  
Based on fresh water @ 68°F  
Maximum working pressure: 360 psi

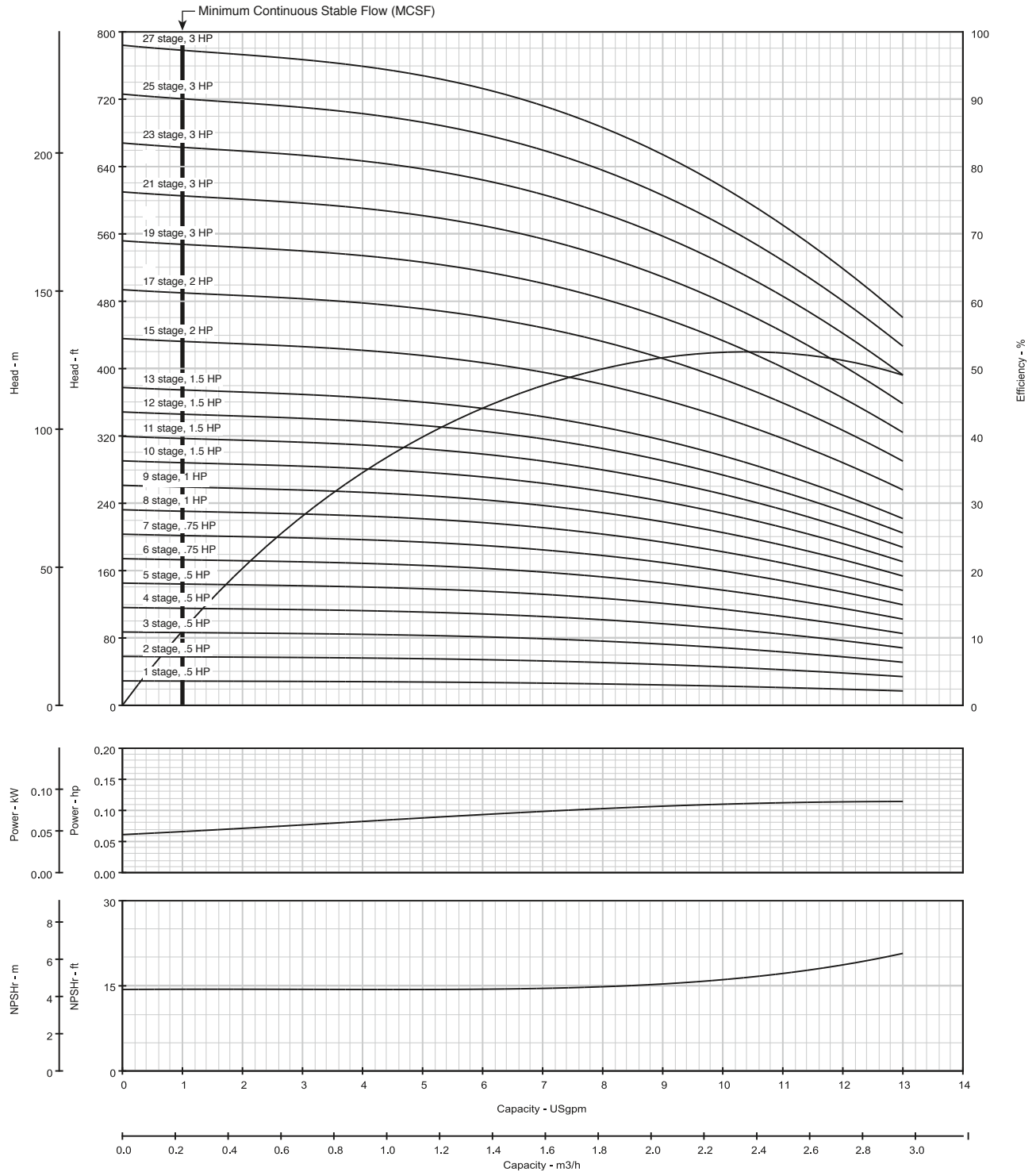

# PVM(X) 3

## VERTICAL MULTISTAGE CENTRIFUGAL PUMPS

### PUMP DIMENSIONS – STANDARD

Model Number	Motor HP	Motor Service Factor	Phase	Voltage	Motor Frame	PVM Cast Iron							PVMX Stainless Steel								
						Dimensions in inches						Weight in Lbs		Dimensions in inches						Weight in Lbs	
						A	B	C	D	E	F	Pump End Only	Pump & Motor	A	B	C	D	E	F	Pump End Only	Pump & Motor
PVM(X)3-2	0.5	1.25	1	115V/208-230V	56C	11.0	9.3	6.0	2.1	22.4	6.0	38	59	11.1	9.3	6.0	2.1	22.5	6.0	32	53
PVM(X)3-2	0.5	1.25	3	208-230V/460V	56C	11.0	10.2	6.6	2.1	23.2	6.6	38	73	11.1	10.2	6.6	2.1	23.3	6.6	32	67
PVM(X)3-3	0.5	1.25	1	115V/208-230V	56C	11.0	9.3	6.0	2.1	22.4	6.0	39	60	11.1	9.3	6.0	2.1	22.5	6.0	33	54
PVM(X)3-3	0.5	1.25	3	208-230V/460V	56C	11.0	10.2	6.6	2.1	23.2	6.6	39	74	11.1	10.2	6.6	2.1	23.3	6.6	33	68
PVM(X)3-4	0.75	1.25	1	115V/208-230V	56C	11.7	9.9	6.0	2.1	23.7	6.0	40	69	11.8	9.9	6.0	2.1	23.8	6.0	35	64
PVM(X)3-4	0.75	1.25	3	208-230V/460V	56C	11.7	10.2	6.6	2.1	23.9	6.6	40	70	11.8	10.2	6.6	2.1	24.0	6.6	35	65
PVM(X)3-5	1	1.25	1	115V/208-230V	56C	12.6	10.2	6.6	2.1	24.8	6.6	42	77	12.8	10.2	6.6	2.1	25.0	6.6	36	71
PVM(X)3-5	1	1.25	3	208-230V/460V	56C	12.6	10.4	7.2	2.1	25.1	7.2	42	95	12.8	10.4	7.2	2.1	25.3	7.2	36	89
PVM(X)3-6	1	1.25	1	115V/208-230V	56C	13.3	10.2	6.6	2.1	25.5	6.6	43	78	13.5	10.2	6.6	2.1	25.7	6.6	37	72
PVM(X)3-6	1	1.25	3	208-230V/460V	56C	13.3	10.4	7.2	2.1	25.8	7.2	43	96	13.5	10.4	7.2	2.1	26.0	7.2	37	90
PVM(X)3-7	1.5	1.15	1	115V/208-230V	56C	14.0	11.2	7.2	2.1	27.2	7.2	44	90	14.2	11.2	7.2	2.1	27.4	7.2	39	85
PVM(X)3-7	1.5	1.15	3	208-230V/460V	56C	14.0	11.2	7.2	2.1	27.2	7.2	44	86	14.2	11.2	7.2	2.1	27.4	7.2	39	81
PVM(X)3-8	1.5	1.15	1	115V/208-230V	56C	14.8	11.2	7.2	2.1	28.0	7.2	46	92	14.9	11.2	7.2	2.1	28.1	7.2	40	86
PVM(X)3-8	1.5	1.15	3	208-230V/460V	56C	14.8	11.2	7.2	2.1	28.0	7.2	46	88	14.9	11.2	7.2	2.1	28.1	7.2	40	82
PVM(X)3-9	1.5	1.15	1	115V/208-230V	56C	16.1	11.2	7.2	2.1	29.3	7.2	47	93	16.2	11.2	7.2	2.1	29.4	7.2	41	87
PVM(X)3-9	1.5	1.15	3	208-230V/460V	56C	16.1	11.2	7.2	2.1	29.3	7.2	47	89	16.2	11.2	7.2	2.1	29.4	7.2	41	83
PVM(X)3-10	2	1.15	1	115V/208-230V	56C	16.8	12.1	7.2	2.1	30.9	7.2	48	101	16.9	12.1	7.2	2.1	31.0	7.2	42	95
PVM(X)3-10	2	1.15	3	208-230V/460V	56C	16.8	12.1	7.2	2.1	30.9	7.2	48	97	16.9	12.1	7.2	2.1	31.0	7.2	42	91
PVM(X)3-11	2	1.15	1	115V/208-230V	56C	17.5	12.1	7.2	2.1	31.6	7.2	49	102	17.6	12.1	7.2	2.1	31.7	7.2	44	97
PVM(X)3-11	2	1.15	3	208-230V/460V	56C	17.5	12.1	7.2	2.1	31.6	7.2	49	98	17.6	12.1	7.2	2.1	31.7	7.2	44	93
PVM(X)3-12	2	1.15	1	115V/208-230V	56C	18.2	12.1	7.2	2.1	32.3	7.2	51	104	18.3	12.1	7.2	2.1	32.4	7.2	45	98
PVM(X)3-12	2	1.15	3	208-230V/460V	56C	18.2	12.1	7.2	2.1	32.3	7.2	51	100	18.3	12.1	7.2	2.1	32.4	7.2	45	94
PVM(X)3-13	3	1.15	1	115V/208-230V	182TC	19.4	15.4	8.9	2.6	37.4	8.9	54	142	19.6	15.4	8.7	2.6	37.6	8.7	48	136
PVM(X)3-13	3	1.15	3	208-230V/460V	182TC	19.4	13.9	8.9	2.6	36.0	8.9	54	122	19.6	13.9	8.7	2.6	36.2	8.7	48	116
PVM(X)3-15	3	1.15	1	115V/208-230V	182TC	20.9	15.4	8.9	2.6	38.9	8.9	56	144	21.0	15.4	8.7	2.6	39.0	8.7	51	139
PVM(X)3-15	3	1.15	3	208-230V/460V	182TC	20.9	13.9	8.9	2.6	37.5	8.9	56	124	21.0	13.9	8.7	2.6	37.6	8.7	51	119
PVM(X)3-17	3	1.15	1	115V/208-230V	182TC	22.3	15.4	8.9	2.6	40.3	8.9	59	147	22.9	15.4	8.7	2.6	40.9	8.7	53	141
PVM(X)3-17	3	1.15	3	208-230V/460V	182TC	22.3	13.9	8.9	2.6	38.9	8.9	59	127	22.9	13.9	8.7	2.6	39.5	8.7	53	121
PVM(X)3-19	5	1.15	1	208-230V	213TC	24.3	15.5	9.6	3.1	42.9	9.6	62	179	24.5	15.5	9.6	3.1	43.1	9.6	56	173
PVM(X)3-19	5	1.15	3	208-230V/460V	184TC	24.3	13.9	8.9	2.6	40.9	8.9	62	130	24.5	13.9	8.9	2.6	41.1	8.9	56	124
PVM(X)3-21	5	1.15	1	208-230V	213TC	25.8	15.5	9.6	3.1	44.4	9.6	64	181	25.9	15.5	9.6	3.1	44.5	9.6	58	175
PVM(X)3-21	5	1.15	3	208-230V/460V	184TC	25.8	13.9	8.9	2.6	42.4	8.9	64	132	25.9	13.9	8.9	2.6	42.5	8.9	58	126
PVM(X)3-23	5	1.15	1	208-230V	213TC	27.2	15.5	9.6	3.1	45.8	9.6	67	184	27.3	15.5	9.6	3.1	45.9	9.6	61	178
PVM(X)3-23	5	1.15	3	208-230V/460V	184TC	27.2	13.9	8.9	2.6	43.8	8.9	67	135	27.3	13.9	8.9	2.6	43.9	8.9	61	129
PVM(X)3-25	5	1.15	1	208-230V	213TC	28.1	15.5	9.6	3.1	46.7	9.6	69	186	27.8	15.5	9.6	3.1	46.4	9.6	64	181
PVM(X)3-25	5	1.15	3	208-230V/460V	184TC	28.1	13.9	8.9	2.6	44.7	8.9	69	137	27.8	13.9	8.9	2.6	44.4	8.9	64	132

# PVM(X) 3 VERTICAL MULTISTAGE CENTRIFUGAL PUMPS

## PUMP DIMENSIONS - STANDARD

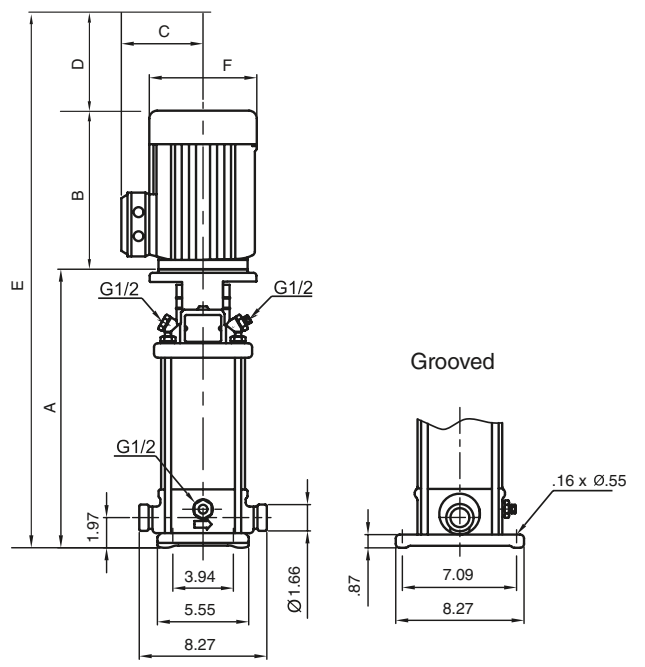
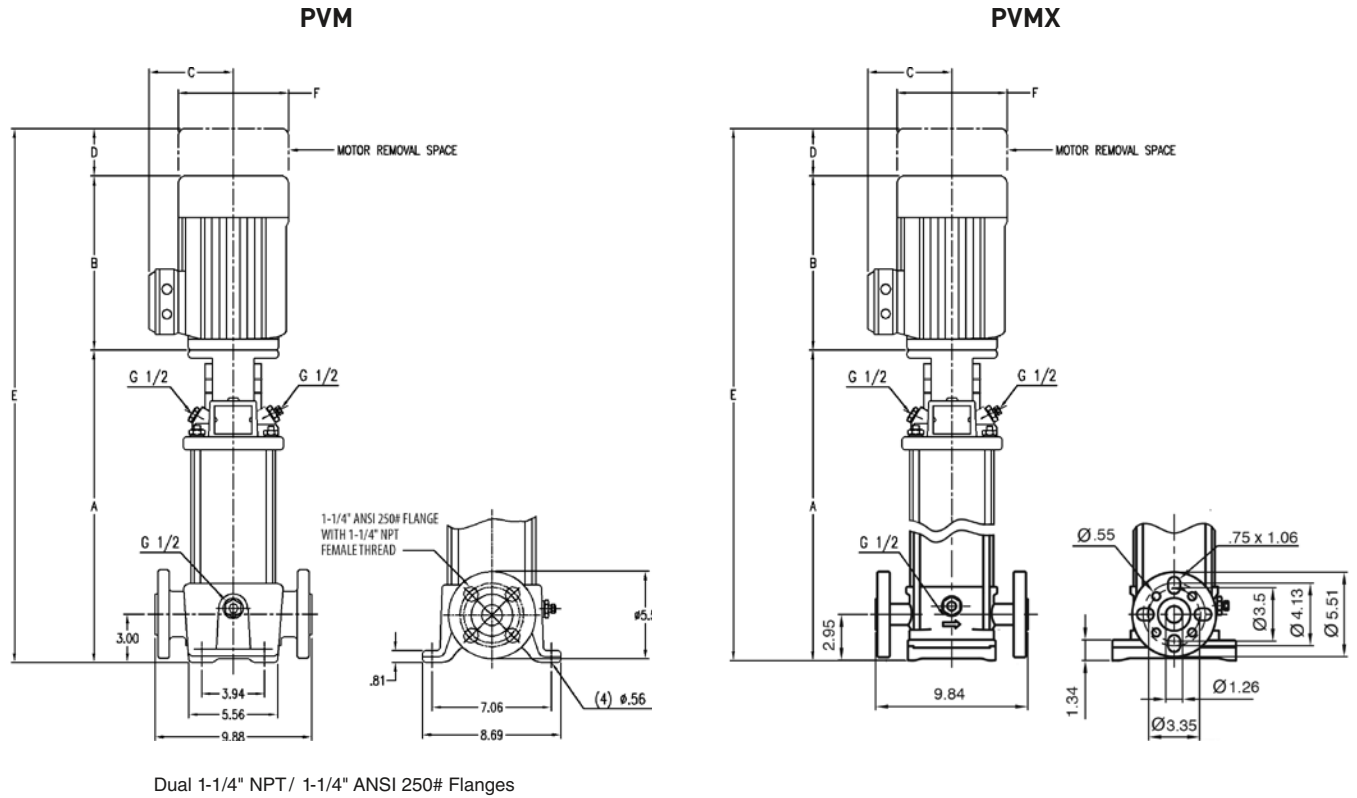

NOTE: G1/2 per ISO-228

# PVM(X) 3

## VERTICAL MULTISTAGE CENTRIFUGAL PUMPS

### PUMP DIMENSIONS – METRIC

Model Number	Motor HP	Motor Service Factor	Phase	Voltage	Motor Frame	PVM Cast Iron							PVMX Stainless Steel								
						Dimensions in mm						Weight in kgs		Dimensions in mm						Weight in kgs	
						A	B	C	D	E	F	Pump End Only	Pump & Motor	A	B	C	D	E	F	Pump End Only	Pump & Motor
PVM(X)3-2	0.5	1.25	1	115V/208-230V	56C	279	236	153	52	568	153	17	27	282	236	153	52	570	153	15	24
PVM(X)3-2	0.5	1.25	3	208-230V/460V	56C	279	258	168	52	590	168	17	33	282	258	168	52	593	168	15	30
PVM(X)3-3	0.5	1.25	1	115V/208-230V	56C	279	236	153	52	568	153	18	27	282	236	153	52	570	153	15	25
PVM(X)3-3	0.5	1.25	3	208-230V/460V	56C	279	258	168	52	590	168	18	34	282	258	168	52	593	168	15	31
PVM(X)3-4	0.75	1.25	1	115V/208-230V	56C	297	252	153	52	601	153	18	31	300	252	153	52	604	153	16	29
PVM(X)3-4	0.75	1.25	3	208-230V/460V	56C	297	258	168	52	608	168	18	32	300	258	168	52	610	168	16	29
PVM(X)3-5	1	1.25	1	115V/208-230V	56C	320	258	168	52	631	168	19	35	325	258	168	52	636	168	16	32
PVM(X)3-5	1	1.25	3	208-230V/460V	56C	320	264	183	52	637	183	19	43	325	264	183	52	642	183	16	40
PVM(X)3-6	1	1.25	1	115V/208-230V	56C	338	258	168	52	648	168	19	35	343	258	168	52	653	168	17	33
PVM(X)3-6	1	1.25	3	208-230V/460V	56C	338	264	183	52	655	183	19	43	343	264	183	52	660	183	17	41
PVM(X)3-7	1.5	1.15	1	115V/208-230V	56C	356	283	182	52	691	182	20	41	361	283	182	52	697	182	17	38
PVM(X)3-7	1.5	1.15	3	208-230V/460V	56C	356	284	183	52	692	183	20	39	361	284	183	52	697	183	17	37
PVM(X)3-8	1.5	1.15	1	115V/208-230V	56C	376	283	182	52	712	182	21	41	378	283	182	52	714	182	18	39
PVM(X)3-8	1.5	1.15	3	208-230V/460V	56C	376	284	183	52	712	183	21	40	378	284	183	52	715	183	18	37
PVM(X)3-9	1.5	1.15	1	115V/208-230V	56C	409	283	182	52	745	182	21	42	411	283	182	52	747	182	19	40
PVM(X)3-9	1.5	1.15	3	208-230V/460V	56C	409	284	183	52	745	183	21	40	411	284	183	52	748	183	19	38
PVM(X)3-10	2	1.15	1	115V/208-230V	56C	427	306	182	52	785	182	22	46	429	306	182	52	788	182	19	43
PVM(X)3-10	2	1.15	3	208-230V/460V	56C	427	306	183	52	785	183	22	44	429	306	183	52	788	183	19	41
PVM(X)3-11	2	1.15	1	115V/208-230V	56C	445	306	182	52	803	182	22	46	447	306	182	52	806	182	20	44
PVM(X)3-11	2	1.15	3	208-230V/460V	56C	445	306	183	52	803	183	22	45	447	306	183	52	806	183	20	42
PVM(X)3-12	2	1.15	1	115V/208-230V	56C	462	306	182	52	821	182	23	47	465	306	182	52	823	182	20	44
PVM(X)3-12	2	1.15	3	208-230V/460V	56C	462	306	183	52	821	183	23	45	465	306	183	52	823	183	20	43
PVM(X)3-13	3	1.15	1	115V/208-230V	182TC	493	392	225	67	951	225	24	64	498	392	220	67	956	220	22	62
PVM(X)3-13	3	1.15	3	208-230V/460V	182TC	493	354	225	67	913	225	24	55	498	354	220	67	918	220	22	53
PVM(X)3-15	3	1.15	1	115V/208-230V	182TC	531	392	225	67	989	225	26	65	533	392	220	67	992	220	23	63
PVM(X)3-15	3	1.15	3	208-230V/460V	182TC	531	354	225	67	951	225	26	56	533	354	220	67	954	220	23	54
PVM(X)3-17	3	1.15	1	115V/208-230V	182TC	566	392	225	67	1025	225	27	67	582	392	220	67	1040	220	24	64
PVM(X)3-17	3	1.15	3	208-230V/460V	182TC	566	354	225	67	987	225	27	58	582	354	220	67	1002	220	24	55
PVM(X)3-19	5	1.15	1	208-230V	213TC	617	394	243	79	1090	243	28	81	622	394	243	79	1095	243	25	78
PVM(X)3-19	5	1.15	3	208-230V/460V	184TC	617	354	225	67	1038	225	28	59	622	354	225	67	1043	225	25	56
PVM(X)3-21	5	1.15	1	208-230V	213TC	655	394	243	79	1128	243	29	82	658	394	243	79	1131	243	26	80
PVM(X)3-21	5	1.15	3	208-230V/460V	184TC	655	354	225	67	1076	225	29	60	658	354	225	67	1078	225	26	57
PVM(X)3-23	5	1.15	1	208-230V	213TC	691	394	243	79	1164	243	30	83	693	394	243	79	1166	243	28	81
PVM(X)3-23	5	1.15	3	208-230V/460V	184TC	691	354	225	67	1111	225	30	61	693	354	225	67	1114	225	28	59
PVM(X)3-25	5	1.15	1	208-230V	213TC	714	394	243	79	1187	243	31	84	706	394	243	79	1179	243	29	82
PVM(X)3-25	5	1.15	3	208-230V/460V	184TC	714	354	226	67	1134	226	31	62	706	354	225	67	1127	225	29	60

# PVM(X) 3 VERTICAL MULTISTAGE CENTRIFUGAL PUMPS

## PUMP DIMENSIONS - METRIC

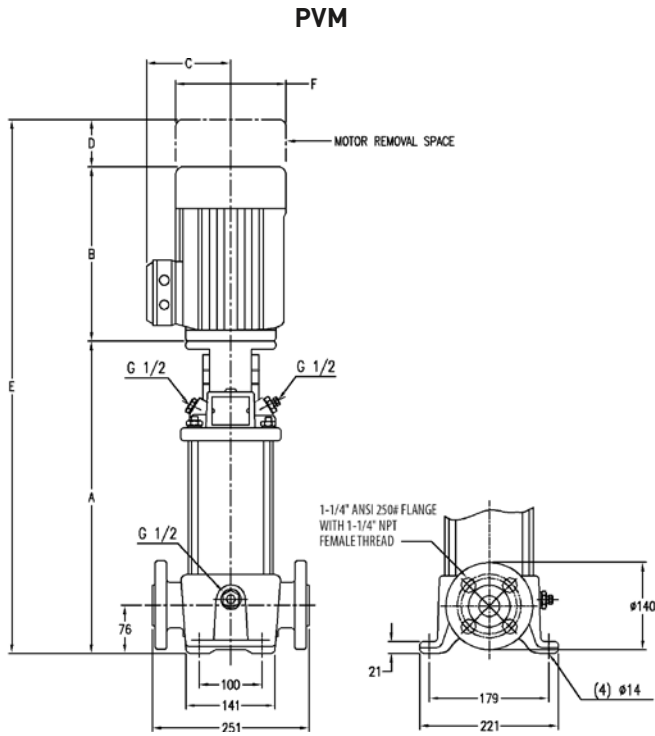

Dual 1-1/4" NPT / 1-1/4" ANSI 250# Flanges

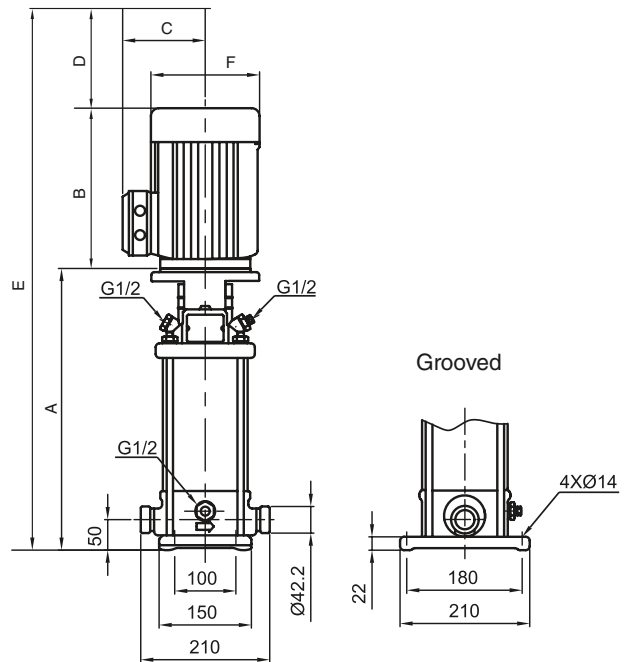
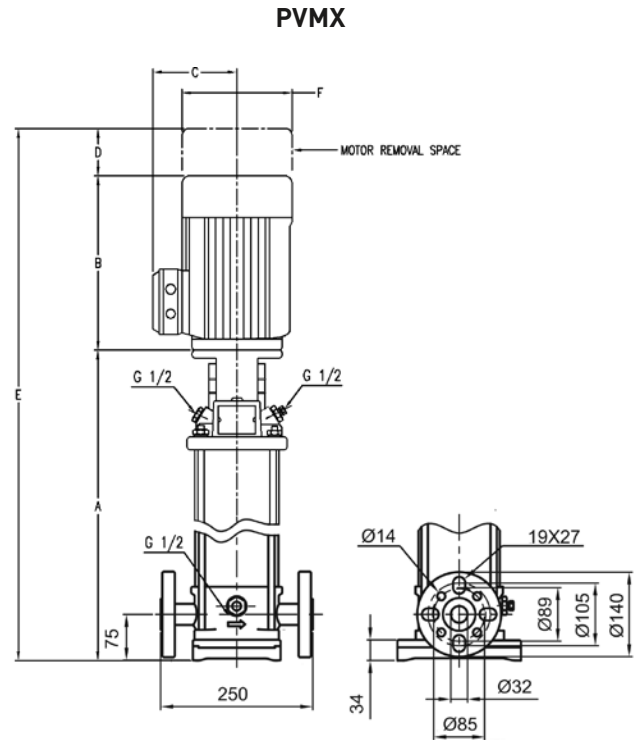

NOTE: G1/2 per ISO-228

# PVM(X) 3

## VERTICAL MULTISTAGE CENTRIFUGAL PUMPS

### HYDRAULIC PERFORMANCE

Curve PVM(X) 3  
Date 10/01/14

Nominal rpm: 3500  
Based on fresh water @ 68° F  
Maximum working pressure: 360 psi

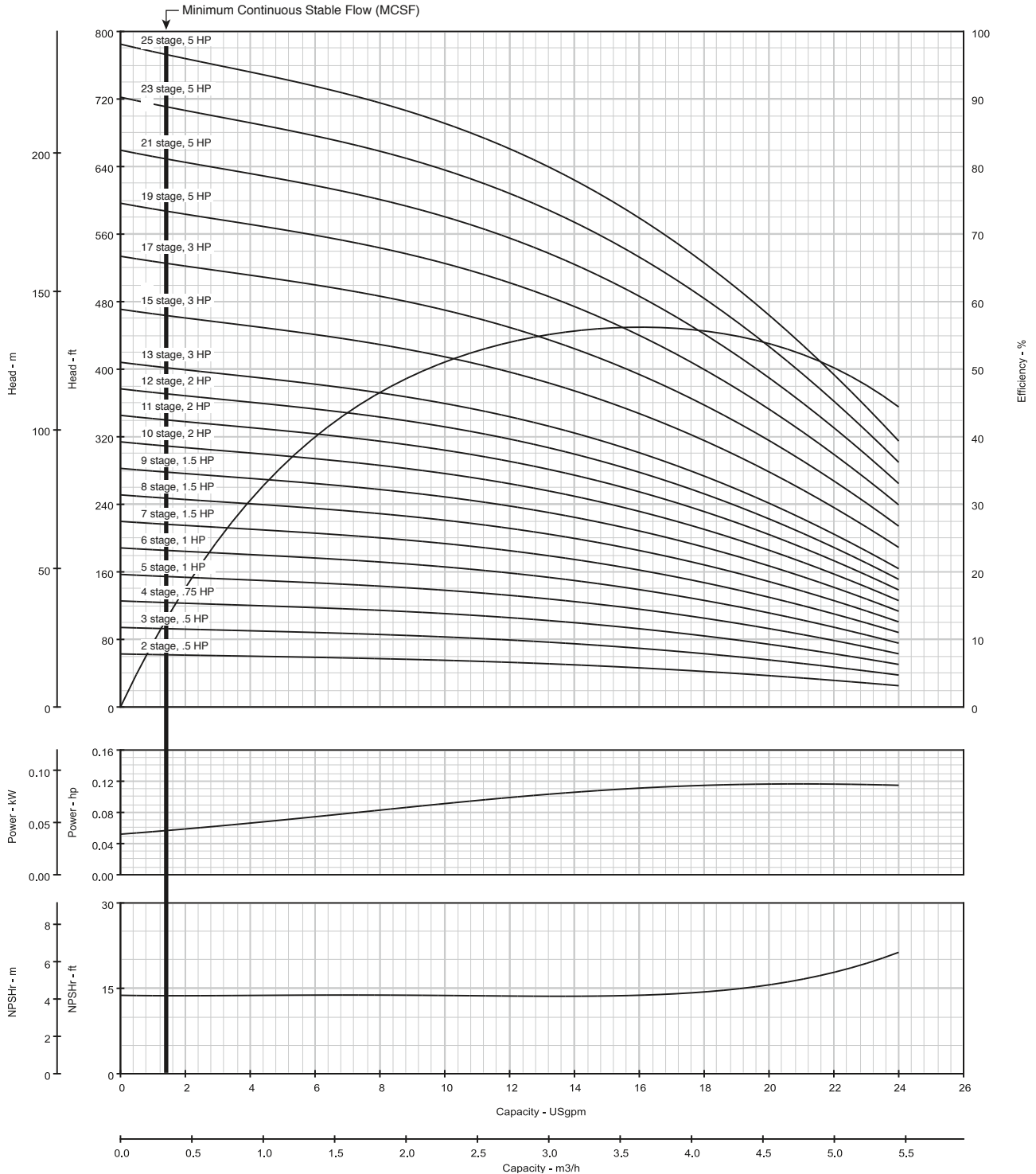

# PVM(X) 5

## VERTICAL MULTISTAGE CENTRIFUGAL PUMPS

### PUMP DIMENSIONS – STANDARD

Model Number	Motor HP	Motor Service Factor	Phase	Voltage	Motor Frame	PVM Cast Iron							PVMX Stainless Steel								
						Dimensions in inches						Weight in Lbs		Dimensions in inches						Weight in Lbs	
						A	B	C	D	E	F	Pump End Only	Pump & Motor	A	B	C	D	E	F	Pump End Only	Pump & Motor
PVM(X)5-2	0.75	1.25	1	115V/208-230V	56C	11.0	9.9	6.0	2.1	23.0	6.0	38	67	11.1	9.9	6.0	2.1	23.1	6.0	32	61
PVM(X)5-2	0.75	1.25	3	208-230V/460V	56C	11.0	10.2	6.6	2.1	23.2	6.6	38	68	11.1	10.2	6.6	2.1	23.3	6.6	32	62
PVM(X)5-3	1	1.25	1	115V/208-230V	56C	12.3	10.2	6.6	2.1	24.5	6.6	39	74	12.4	10.2	6.6	2.1	24.6	6.6	33	68
PVM(X)5-3	1	1.25	3	208-230V/460V	56C	12.3	10.4	7.2	2.1	24.8	7.2	39	92	12.4	10.4	7.2	2.1	24.9	7.2	33	86
PVM(X)5-4	1.5	1.15	1	115V/208-230V	56C	13.3	11.2	7.2	2.1	26.5	7.2	40	86	13.5	11.2	7.2	2.1	26.7	7.2	35	81
PVM(X)5-4	1.5	1.15	3	208-230V/460V	56C	13.3	11.2	7.2	2.1	26.5	7.2	40	82	13.5	11.2	7.2	2.1	26.7	7.2	35	77
PVM(X)5-5	2	1.15	1	115V/208-230V	56C	15.0	12.1	7.2	2.1	29.1	7.2	42	95	15.2	12.1	7.2	2.1	29.3	7.2	36	89
PVM(X)5-5	2	1.15	3	208-230V/460V	56C	15.0	12.1	7.2	2.1	29.1	7.2	42	91	15.2	12.1	7.2	2.1	29.3	7.2	36	85
PVM(X)5-6	2	1.15	1	115V/208-230V	56C	16.1	12.1	7.2	2.1	30.2	7.2	43	96	16.2	12.1	7.2	2.1	30.3	7.2	37	90
PVM(X)5-6	2	1.15	3	208-230V/460V	56C	16.1	12.1	7.2	2.1	30.2	7.2	43	92	16.2	12.1	7.2	2.1	30.3	7.2	37	86
PVM(X)5-7	3	1.15	1	115V/208-230V	182TC	17.7	15.4	8.9	2.6	35.7	8.9	46	134	17.8	15.4	8.7	2.6	35.8	8.7	40	128
PVM(X)5-7	3	1.15	3	208-230V/460V	182TC	17.7	13.9	8.9	2.6	34.3	8.9	46	114	17.8	13.9	8.7	2.6	34.4	8.7	40	108
PVM(X)5-8	3	1.15	1	115V/208-230V	182TC	18.7	15.4	8.9	2.6	36.7	8.9	47	135	18.8	15.4	8.7	2.6	36.8	8.7	42	130
PVM(X)5-8	3	1.15	3	208-230V/460V	182TC	18.7	13.9	8.9	2.6	35.3	8.9	47	115	18.8	13.9	8.7	2.6	35.4	8.7	42	110
PVM(X)5-9	3	1.15	1	115V/208-230V	182TC	19.8	15.4	8.9	2.6	37.8	8.9	49	137	19.9	15.4	8.7	2.6	37.9	8.7	43	131
PVM(X)5-9	3	1.15	3	208-230V/460V	182TC	19.8	13.9	8.9	2.6	36.4	8.9	49	117	19.9	13.9	8.7	2.6	36.5	8.7	43	111
PVM(X)5-10	5	1.15	1	208-230V	213TC	21.0	15.5	9.6	3.1	39.6	9.6	50	167	21.2	15.5	9.6	3.1	39.8	9.6	44	161
PVM(X)5-10	5	1.15	3	208-230V/460V	184TC	21.0	13.9	8.9	2.6	37.6	8.9	50	118	21.2	13.9	8.9	2.6	37.8	8.9	44	112
PVM(X)5-11	5	1.15	1	208-230V	213TC	22.1	15.5	9.6	3.1	40.7	9.6	51	168	22.2	15.5	9.6	3.1	40.8	9.6	45	162
PVM(X)5-11	5	1.15	3	208-230V/460V	184TC	22.1	13.9	8.9	2.6	38.7	8.9	51	119	22.2	13.9	8.9	2.6	38.8	8.9	45	113
PVM(X)5-12	5	1.15	1	208-230V	213TC	23.1	15.5	9.6	3.1	41.7	9.6	52	169	23.3	15.5	9.6	3.1	41.9	9.6	47	164
PVM(X)5-12	5	1.15	3	208-230V/460V	184TC	23.1	13.9	8.9	2.6	39.7	8.9	52	120	23.3	13.9	8.9	2.6	39.9	8.9	47	115
PVM(X)5-13	5	1.15	1	208-230V	213TC	24.2	15.5	9.6	3.1	42.8	9.6	54	171	24.4	15.5	9.6	3.1	43.0	9.6	48	165
PVM(X)5-13	5	1.15	3	208-230V/460V	184TC	24.2	13.9	8.9	2.6	40.8	8.9	54	122	24.4	13.9	8.9	2.6	41.0	8.9	48	116
PVM(X)5-14	5	1.15	1	208-230V	213TC	25.3	15.5	9.6	3.1	43.9	9.6	55	172	25.4	15.5	9.6	3.1	44.0	9.6	49	166
PVM(X)5-14	5	1.15	3	208-230V/460V	184TC	25.3	13.9	8.9	2.6	41.9	8.9	55	123	25.4	13.9	8.9	2.6	42.0	8.9	49	117
PVM(X)5-15	5	1.15	1	208-230V	213TC	26.3	15.5	9.6	3.1	44.9	9.6	56	173	26.5	15.5	9.6	3.1	45.1	9.6	51	168
PVM(X)5-15	5	1.15	3	208-230V/460V	184TC	26.3	13.9	8.9	2.6	42.9	8.9	56	124	26.5	13.9	8.9	2.6	43.1	8.9	51	119
PVM(X)5-16	5	1.15	1	208-230V	213TC	27.4	15.5	9.6	3.1	46.0	9.6	58	175	27.5	15.5	9.6	3.1	46.1	9.6	52	169
PVM(X)5-16	5	1.15	3	208-230V/460V	184TC	27.4	13.9	8.9	2.6	44.0	8.9	58	126	27.5	13.9	8.9	2.6	44.1	8.9	52	120
PVM(X)5-18	7.5	1.15	1	208-230V	213TC	29.4	15.5	8.7	3.1	48.0	8.7	60	177	29.4	15.5	8.7	3.1	48.0	8.7	55	172
PVM(X)5-18	7.5	1.15	3	208-230V/460V	213TC	29.4	15.5	9.6	3.1	48.1	9.6	60	158	29.4	15.5	9.6	3.1	48.1	9.6	55	153
PVM(X)5-20	7.5	1.15	1	208-230V	213TC	31.5	15.5	8.7	3.1	50.1	8.7	63	180	31.6	15.5	8.7	3.1	50.2	8.7	57	174
PVM(X)5-20	7.5	1.15	3	208-230V/460V	213TC	21.5	15.5	9.6	3.1	40.2	9.6	63	161	31.6	15.5	9.6	3.1	50.3	9.6	57	155
PVM(X)5-22	7.5	1.15	1	208-230V	213TC	33.6	15.5	8.7	3.1	52.2	8.7	65	182	33.8	15.5	8.7	3.1	52.4	8.7	60	177
PVM(X)5-22	7.5	1.15	3	208-230V/460V	213TC	33.6	15.5	9.6	3.1	52.3	9.6	65	163	33.8	15.5	9.6	3.1	52.5	9.6	60	158
PVM(X)5-24	7.5	1.15	1	208-230V	213TC	35.7	15.5	8.7	3.1	54.3	8.7	68	185	35.9	15.5	8.7	3.1	54.5	8.7	62	179
PVM(X)5-24	7.5	1.15	3	208-230V/460V	213TC	35.7	15.5	9.6	3.1	54.4	9.6	68	166	35.9	15.5	9.6	3.1	54.6	9.6	62	160



# PVM(X) 5

## VERTICAL MULTISTAGE CENTRIFUGAL PUMPS

### PUMP DIMENSIONS – METRIC

Model Number	Motor HP	Motor Service Factor	Phase	Voltage	Motor Frame	PVM Cast Iron								PVMX Stainless Steel							
						Dimensions in mm						Weight in kgs		Dimensions in mm						Weight in kgs	
						A	B	C	D	E	F	Pump End Only	Pump & Motor	A	B	C	D	E	F	Pump End Only	Pump & Motor
PVM(X)5-2	0.75	1.25	1	115V/208-230V	56C	279	252	153	52	584	153	17	30	282	252	153	52	586	153	15	28
PVM(X)5-2	0.75	1.25	3	208-230V/460V	56C	279	258	168	52	590	168	17	31	282	258	168	52	593	168	15	28
PVM(X)5-3	1	1.25	1	115V/208-230V	56C	312	258	168	52	623	168	18	34	315	258	168	52	625	168	15	31
PVM(X)5-3	1	1.25	3	208-230V/460V	56C	312	264	183	52	629	183	18	42	315	264	183	52	632	183	15	39
PVM(X)5-4	1.5	1.15	1	115V/208-230V	56C	338	283	182	52	674	182	18	39	343	283	182	52	679	182	16	37
PVM(X)5-4	1.5	1.15	3	208-230V/460V	56C	338	284	183	52	674	183	18	37	343	284	183	52	679	183	16	35
PVM(X)5-5	2	1.15	1	115V/208-230V	56C	381	306	182	52	739	182	19	43	386	306	182	52	745	182	16	40
PVM(X)5-5	2	1.15	3	208-230V/460V	56C	381	306	183	52	739	183	19	41	386	306	183	52	745	183	16	39
PVM(X)5-6	2	1.15	1	115V/208-230V	56C	409	306	182	52	767	182	19	43	411	306	182	52	770	182	17	41
PVM(X)5-6	2	1.15	3	208-230V/460V	56C	409	306	183	52	767	183	19	42	411	306	183	52	770	183	17	39
PVM(X)5-7	3	1.15	1	115V/208-230V	182TC	450	392	225	67	908	225	21	61	452	392	220	67	910	220	18	58
PVM(X)5-7	3	1.15	3	208-230V/460V	182TC	450	354	225	67	870	225	21	52	452	354	220	67	873	220	18	49
PVM(X)5-8	3	1.15	1	115V/208-230V	182TC	475	392	225	67	933	225	21	61	478	392	220	67	936	220	19	59
PVM(X)5-8	3	1.15	3	208-230V/460V	182TC	475	354	225	67	895	225	21	52	478	354	220	67	898	220	19	50
PVM(X)5-9	3	1.15	1	115V/208-230V	182TC	503	392	225	67	961	225	22	62	505	392	220	67	964	220	19	59
PVM(X)5-9	3	1.15	3	208-230V/460V	182TC	503	354	225	67	923	225	22	53	505	354	220	67	926	220	19	50
PVM(X)5-10	5	1.15	1	208-230V	213TC	533	394	243	79	1006	243	23	76	538	394	243	79	1012	243	20	73
PVM(X)5-10	5	1.15	3	208-230V/460V	184TC	533	354	225	67	954	225	23	53	538	354	225	67	959	225	20	51
PVM(X)5-11	5	1.15	1	208-230V	213TC	561	394	243	79	1034	243	23	76	564	394	243	79	1037	243	21	74
PVM(X)5-11	5	1.15	3	208-230V/460V	184TC	561	354	225	67	982	225	23	54	564	354	225	67	984	225	21	51
PVM(X)5-12	5	1.15	1	208-230V	213TC	587	394	243	79	1060	243	24	77	592	394	243	79	1065	243	21	74
PVM(X)5-12	5	1.15	3	208-230V/460V	184TC	587	354	225	67	1007	225	24	55	592	354	225	67	1012	225	21	52
PVM(X)5-13	5	1.15	1	208-230V	213TC	615	394	243	79	1088	243	24	77	620	394	243	79	1093	243	22	75
PVM(X)5-13	5	1.15	3	208-230V/460V	184TC	615	354	225	67	1035	225	24	55	620	354	225	67	1040	225	22	53
PVM(X)5-14	5	1.15	1	208-230V	213TC	643	394	243	79	1116	243	25	78	645	394	243	79	1118	243	22	75
PVM(X)5-14	5	1.15	3	208-230V/460V	184TC	643	354	225	67	1063	225	25	56	645	354	225	67	1066	225	22	53
PVM(X)5-15	5	1.15	1	208-230V	213TC	668	394	243	79	1141	243	26	79	673	394	243	79	1146	243	23	76
PVM(X)5-15	5	1.15	3	208-230V/460V	184TC	668	354	225	67	1089	225	26	56	673	354	225	67	1094	225	23	54
PVM(X)5-16	5	1.15	1	208-230V	213TC	696	394	243	79	1169	243	26	79	699	394	243	79	1172	243	24	77
PVM(X)5-16	5	1.15	3	208-230V/460V	184TC	696	354	225	67	1116	225	26	57	699	354	225	67	1119	225	24	54
PVM(X)5-18	7.5	1.15	1	208-230V	213TC	747	394	220	79	1220	220	27	80	747	394	220	79	1220	220	25	78
PVM(X)5-18	7.5	1.15	3	208-230V/460V	213TC	747	395	243	79	1221	243	27	72	747	395	243	79	1221	243	25	69
PVM(X)5-20	7.5	1.15	1	208-230V	213TC	800	394	220	79	1273	220	28	82	803	394	220	79	1276	220	26	79
PVM(X)5-20	7.5	1.15	3	208-230V/460V	213TC	546	395	243	79	1020	243	28	73	803	395	243	79	1277	243	26	70
PVM(X)5-22	7.5	1.15	1	208-230V	213TC	853	394	220	79	1327	220	30	83	859	394	220	79	1332	220	27	80
PVM(X)5-22	7.5	1.15	3	208-230V/460V	213TC	853	395	243	79	1328	243	30	74	859	395	243	79	1333	243	27	72
PVM(X)5-24	7.5	1.15	1	208-230V	213TC	907	394	220	79	1380	220	31	84	912	394	220	79	1385	220	28	81
PVM(X)5-24	7.5	1.15	3	208-230V/460V	213TC	907	395	243	79	1381	243	31	75	912	395	243	79	1386	243	28	73

# PVM(X) 5 VERTICAL MULTISTAGE CENTRIFUGAL PUMPS

## PUMP DIMENSIONS - METRIC

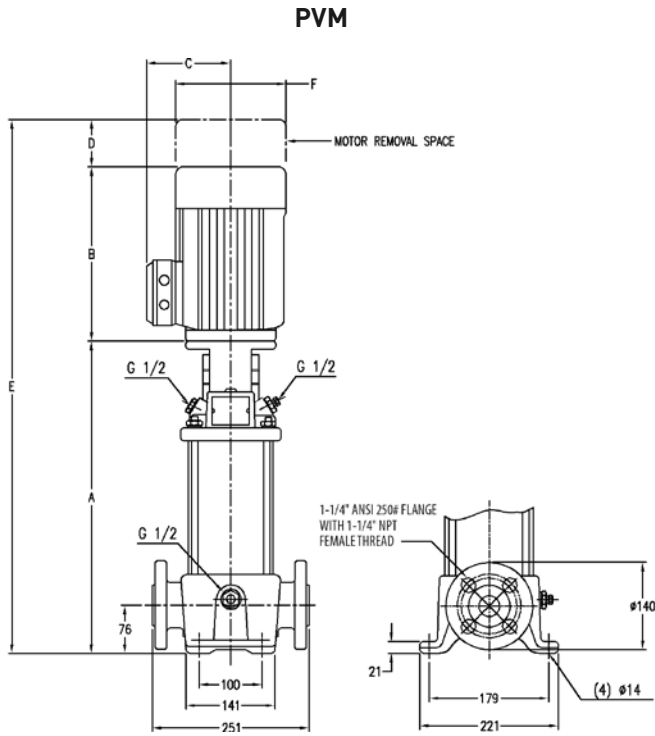

Dual 1-1/4" NPT / 1-1/4" ANSI 250# Flanges

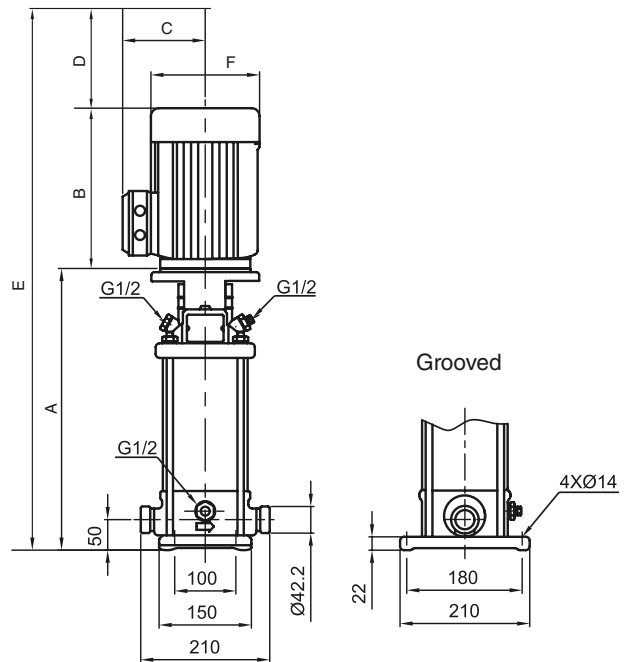
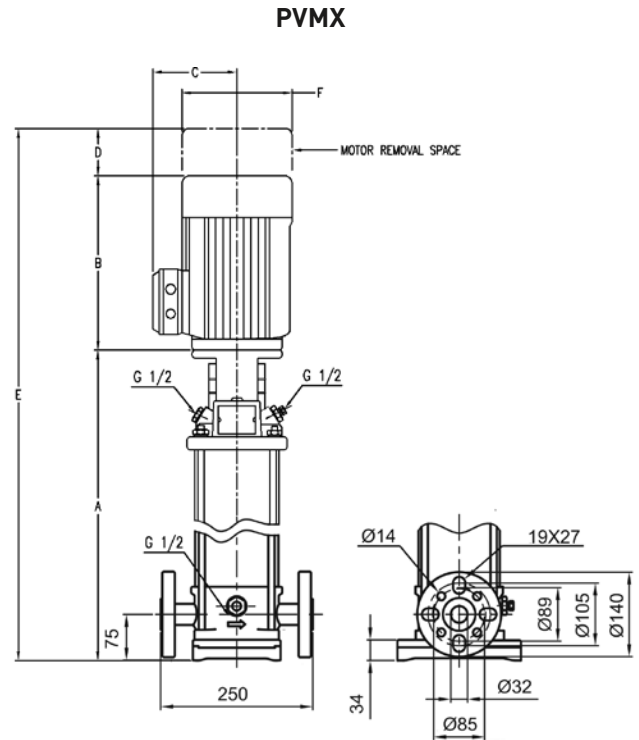

NOTE: G1/2 per ISO-228

# PVM(X) 5

## VERTICAL MULTISTAGE CENTRIFUGAL PUMPS

### HYDRAULIC PERFORMANCE

Curve PVM(X) 5  
Date 10/01/14

Nominal rpm: 3500  
Based on fresh water @ 68°F  
Maximum working pressure: 360 psi

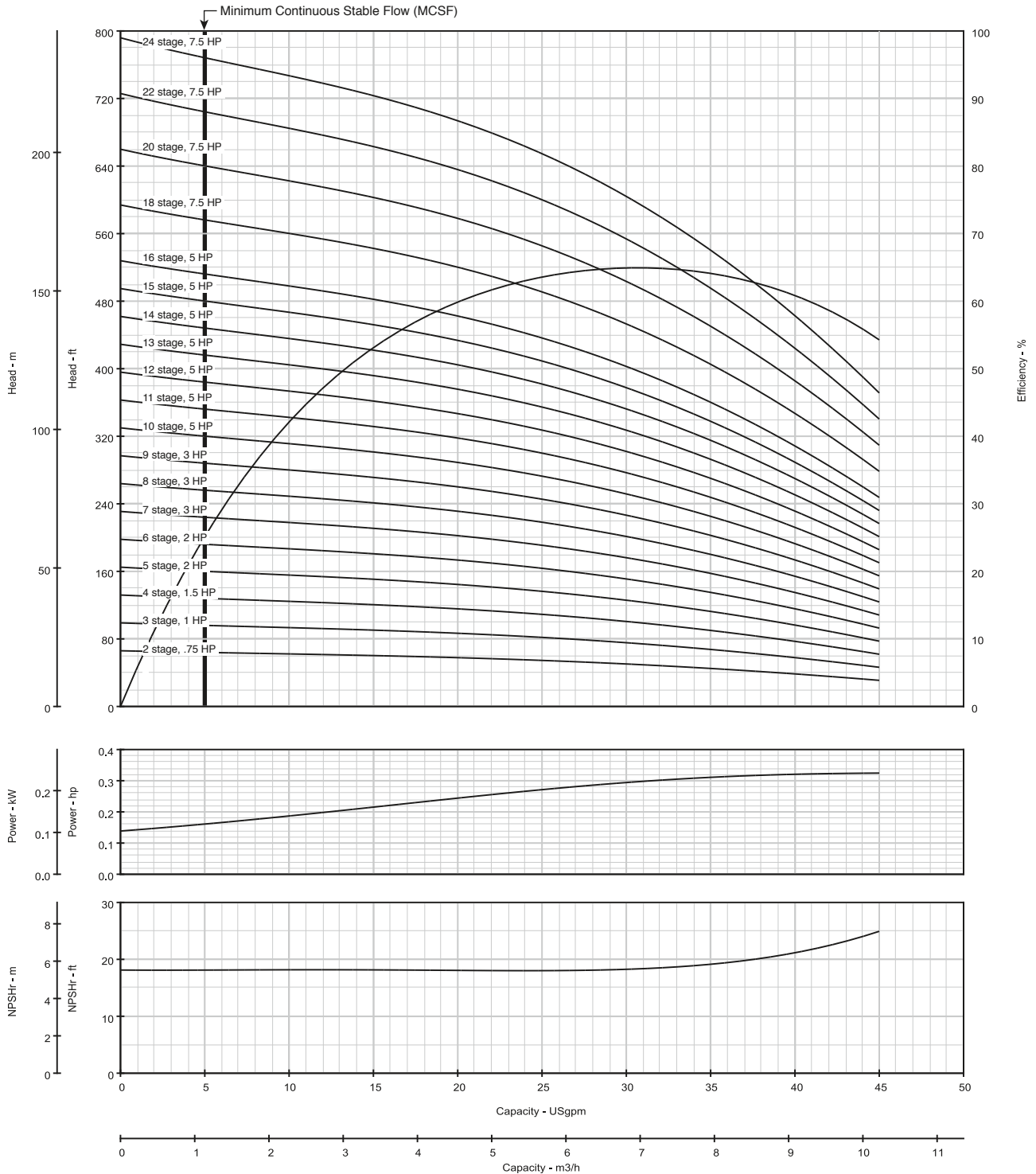

# PVM(X) 10

## VERTICAL MULTISTAGE CENTRIFUGAL PUMPS

### PUMP DIMENSIONS – STANDARD

Model Number	Motor HP	Motor Service Factor	Phase	Voltage	Motor Frame	PVM Cast Iron							PVMX Stainless Steel								
						Dimensions in inches						Weight in Lbs		Dimensions in inches						Weight in Lbs	
						A	B	C	D	E	F	Pump End Only	Pump & Motor	A	B	C	D	E	F	Pump End Only	Pump & Motor
PVM(X)10-1	0.75	1.25	1	115V/208-230V	56C	13.7	9.9	6.0	2.1	25.7	6.0	61	90	14.1	9.9	6.0	2.1	26.1	6.0	50	79
PVM(X)10-1	0.75	1.25	3	208-230V/460V	56C	13.7	10.2	6.6	2.1	25.9	6.6	61	91	14.1	10.2	6.6	2.1	26.3	6.6	50	80
PVM(X)10-2	1.5	1.15	1	115V/208-230V	56C	14.3	11.2	7.2	2.1	27.5	7.2	67	113	14.7	11.2	7.2	2.1	27.9	7.2	56	102
PVM(X)10-2	1.5	1.15	3	208-230V/460V	56C	14.3	11.2	7.2	2.1	27.5	7.2	67	109	14.7	11.2	7.2	2.1	27.9	7.2	56	98
PVM(X)10-3	3	1.15	1	115V/208-230V	182TC	16.0	15.4	8.9	2.6	34.0	8.9	74	162	16.4	15.4	8.7	2.6	34.4	8.7	63	151
PVM(X)10-3	3	1.15	3	208-230V/460V	182TC	16.0	13.9	8.9	2.6	32.6	8.9	74	142	16.4	13.9	8.7	2.6	33.0	8.7	63	131
PVM(X)10-4	3	1.15	1	115V/208-230V	182TC	17.4	15.4	8.9	2.6	35.4	8.9	80	168	17.7	15.4	8.7	2.6	35.7	8.7	69	157
PVM(X)10-4	3	1.15	3	208-230V/460V	182TC	17.4	13.9	8.9	2.6	34.0	8.9	80	148	17.7	13.9	8.7	2.6	34.3	8.7	69	137
PVM(X)10-5	5	1.15	1	208-230V	213TC	18.5	15.5	9.6	3.1	37.1	9.6	86	203	18.9	15.5	9.6	3.1	37.5	9.6	75	192
PVM(X)10-5	5	1.15	3	208-230V/460V	184TC	18.5	13.9	8.9	2.6	35.1	8.9	86	154	18.9	13.9	8.9	2.6	35.5	8.9	75	143
PVM(X)10-6	5	1.15	1	208-230V	213TC	19.7	15.5	9.6	3.1	38.3	9.6	92	209	20.1	15.5	9.6	3.1	38.7	9.6	81	198
PVM(X)10-6	5	1.15	3	208-230V/460V	184TC	19.7	13.9	8.9	2.6	36.3	8.9	92	160	20.1	13.9	8.9	2.6	36.7	8.9	81	149
PVM(X)10-7	7.5	1.15	1	208-230V	213TC	20.9	15.5	8.7	3.1	39.5	8.7	98	215	21.2	15.5	8.7	3.1	39.8	8.7	87	204
PVM(X)10-7	7.5	1.15	3	208-230V/460V	213TC	20.9	15.5	9.6	3.1	39.6	9.6	98	196	21.2	15.5	9.6	3.1	39.9	9.6	87	185
PVM(X)10-8	7.5	1.15	1	208-230V	213TC	22.0	15.5	8.7	3.1	40.6	8.7	104	221	22.4	15.5	8.7	3.1	41.0	8.7	93	210
PVM(X)10-8	7.5	1.15	3	208-230V/460V	213TC	22.0	15.5	9.6	3.1	40.7	9.6	104	202	22.4	15.5	9.6	3.1	41.1	9.6	93	191
PVM(X)10-9	7.5	1.15	1	208-230V	213TC	23.2	15.5	8.7	3.1	41.8	8.7	110	227	23.5	15.5	8.7	3.1	42.1	8.7	99	216
PVM(X)10-9	7.5	1.15	3	208-230V/460V	213TC	23.2	15.5	9.6	3.1	41.9	9.6	110	208	23.6	15.5	9.6	3.1	42.3	9.6	99	197
PVM(X)10-10	7.5	1.15	1	208-230V	213TC	24.4	15.5	8.7	3.1	43.0	8.7	116	233	24.8	15.5	8.7	3.1	43.4	8.7	105	222
PVM(X)10-10	7.5	1.15	3	208-230V/460V	213TC	24.4	15.5	9.6	3.1	43.1	9.6	116	214	24.8	15.5	9.6	3.1	43.5	9.6	105	203
PVM(X)10-12	10	1.15	1	208-230V	215TC	26.8	16.6	9.6	3.1	46.5	9.6	129	264	27.2	16.6	9.6	3.1	46.9	9.6	117	252
PVM(X)10-12	10	1.15	3	208-230V/460V	215TC	26.8	15.5	9.6	3.1	45.5	9.6	129	254	27.2	15.5	9.6	3.1	45.9	9.6	117	242
PVM(X)10-14	15	1.15	3	208-230V/460V	254TC	31.0	20.0	12.9	3.8	54.8	12.9	141	416	31.3	20.0	12.9	3.8	55.1	12.9	130	405
PVM(X)10-16	15	1.15	3	208-230V/460V	254TC	33.3	20.0	12.9	3.8	57.1	12.9	153	428	33.7	20.0	12.9	3.8	57.5	12.9	142	417

# PVM(X) 10

## VERTICAL MULTISTAGE CENTRIFUGAL PUMPS

### PUMP DIMENSIONS - STANDARD

**PVM**

**PVMX**

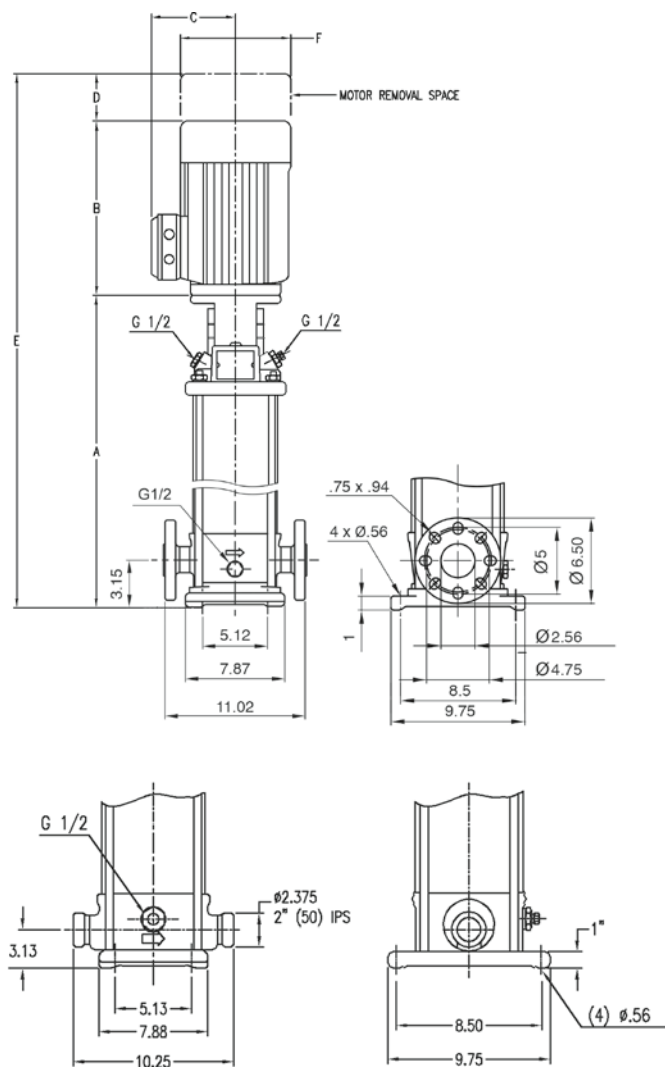
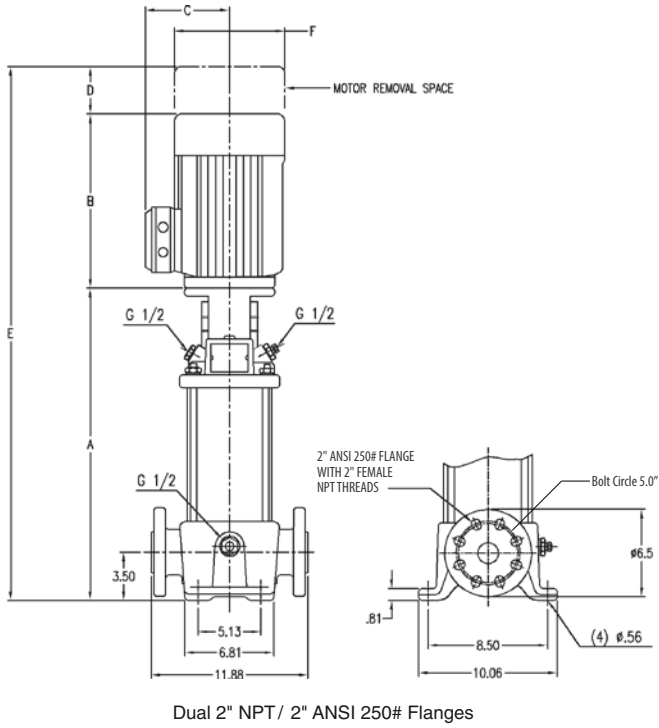

NOTE: G1/2 per ISO-228

# PVM(X) 10

## VERTICAL MULTISTAGE CENTRIFUGAL PUMPS

### PUMP DIMENSIONS - METRIC

Model Number	Motor HP	Motor Service Factor	Phase	Voltage	Motor Frame	PVM Cast Iron								PVMX Stainless Steel							
						Dimensions in mm						Weight in kgs		Dimensions in mm						Weight in kgs	
						A	B	C	D	E	F	Pump End Only	Pump & Motor	A	B	C	D	E	F	Pump End Only	Pump & Motor
PVM(X)10-1	0.75	1.25	1	115V/208-230V	56C	348	252	153	52	652	153	28	41	358	252	153	52	662	153	23	36
PVM(X)10-1	0.75	1.25	3	208-230V/460V	56C	348	258	168	52	659	168	28	41	358	258	168	52	669	168	23	36
PVM(X)10-2	1.5	1.15	1	115V/208-230V	56C	363	283	182	52	699	182	30	51	373	283	182	52	709	182	25	46
PVM(X)10-2	1.5	1.15	3	208-230V/460V	56C	363	284	183	52	699	183	30	49	373	284	183	52	709	183	25	44
PVM(X)10-3	3	1.15	1	115V/208-230V	182TC	406	392	225	67	865	225	33	73	417	392	220	67	875	220	28	68
PVM(X)10-3	3	1.15	3	208-230V/460V	182TC	406	354	225	67	827	225	33	64	417	354	220	67	837	220	28	59
PVM(X)10-4	3	1.15	1	115V/208-230V	182TC	442	392	225	67	900	225	36	76	450	392	220	67	908	220	31	71
PVM(X)10-4	3	1.15	3	208-230V/460V	182TC	442	354	225	67	862	225	36	67	450	354	220	67	870	220	31	62
PVM(X)10-5	5	1.15	1	208-230V	213TC	470	394	243	79	943	243	39	92	480	394	243	79	953	243	34	87
PVM(X)10-5	5	1.15	3	208-230V/460V	184TC	470	354	225	67	890	225	39	70	480	354	225	67	901	225	34	65
PVM(X)10-6	5	1.15	1	208-230V	213TC	500	394	243	79	973	243	42	95	511	394	243	79	984	243	37	90
PVM(X)10-6	5	1.15	3	208-230V/460V	184TC	500	354	225	67	921	225	42	72	511	354	225	67	931	225	37	67
PVM(X)10-7	7.5	1.15	1	208-230V	213TC	531	394	220	79	1004	220	44	97	538	394	220	79	1012	220	39	92
PVM(X)10-7	7.5	1.15	3	208-230V/460V	213TC	531	395	243	79	1005	243	44	89	538	395	243	79	1013	243	39	84
PVM(X)10-8	7.5	1.15	1	208-230V	213TC	559	394	220	79	1032	220	47	100	569	394	220	79	1042	220	42	95
PVM(X)10-8	7.5	1.15	3	208-230V/460V	213TC	559	395	243	79	1033	243	47	91	569	395	243	79	1043	243	42	86
PVM(X)10-9	7.5	1.15	1	208-230V	213TC	589	394	220	79	1062	220	50	103	597	394	220	79	1070	220	45	98
PVM(X)10-9	7.5	1.15	3	208-230V/460V	213TC	589	395	243	79	1063	243	50	94	599	395	243	79	1074	243	45	89
PVM(X)10-10	7.5	1.15	1	208-230V	213TC	620	394	220	79	1093	220	52	106	630	394	220	79	1103	220	47	100
PVM(X)10-10	7.5	1.15	3	208-230V/460V	213TC	620	395	243	79	1094	243	52	97	630	395	243	79	1104	243	47	92
PVM(X)10-12	10	1.15	1	208-230V	215TC	681	422	243	79	1182	243	58	120	691	422	243	79	1192	243	53	114
PVM(X)10-12	10	1.15	3	208-230V/460V	215TC	681	394	243	79	1155	243	58	115	691	394	243	79	1165	243	53	110
PVM(X)10-14	15	1.15	3	208-230V/460V	254TC	787	509	329	95	1391	329	64	189	795	509	329	95	1399	329	59	184
PVM(X)10-16	15	1.15	3	208-230V/460V	254TC	846	509	329	95	1450	329	69	194	856	509	329	95	1460	329	64	189

# PVM(X) 10

## VERTICAL MULTISTAGE CENTRIFUGAL PUMPS

### PUMP DIMENSIONS - METRIC

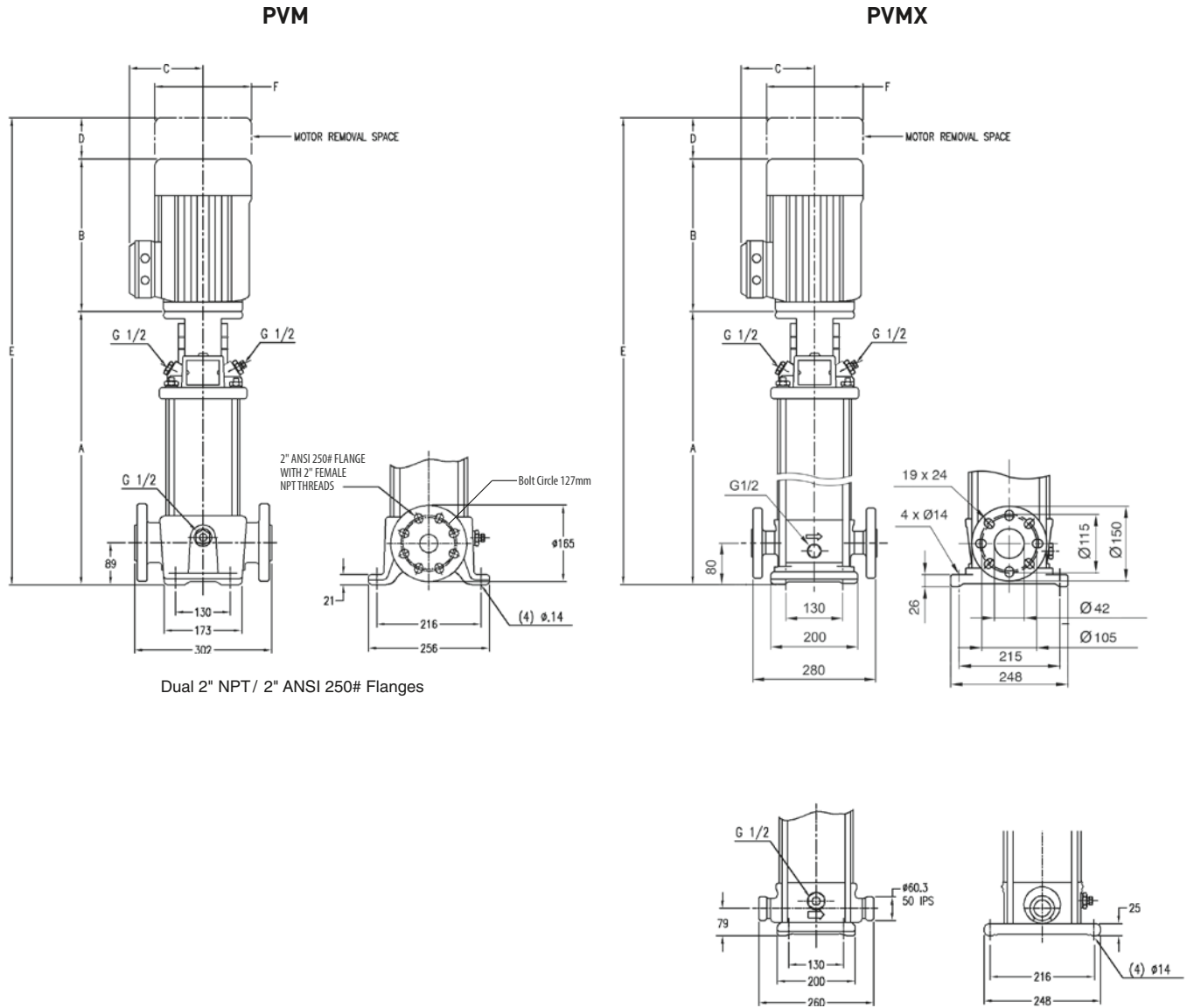

NOTE: G1/2 per ISO-228

# PVM(X) 10

## VERTICAL MULTISTAGE CENTRIFUGAL PUMPS

### HYDRAULIC PERFORMANCE

Curve PVM(X) 10  
Date 10/01/14

Nominal rpm: 3500  
Based on fresh water @ 68° F  
Maximum working pressure: 360 psi

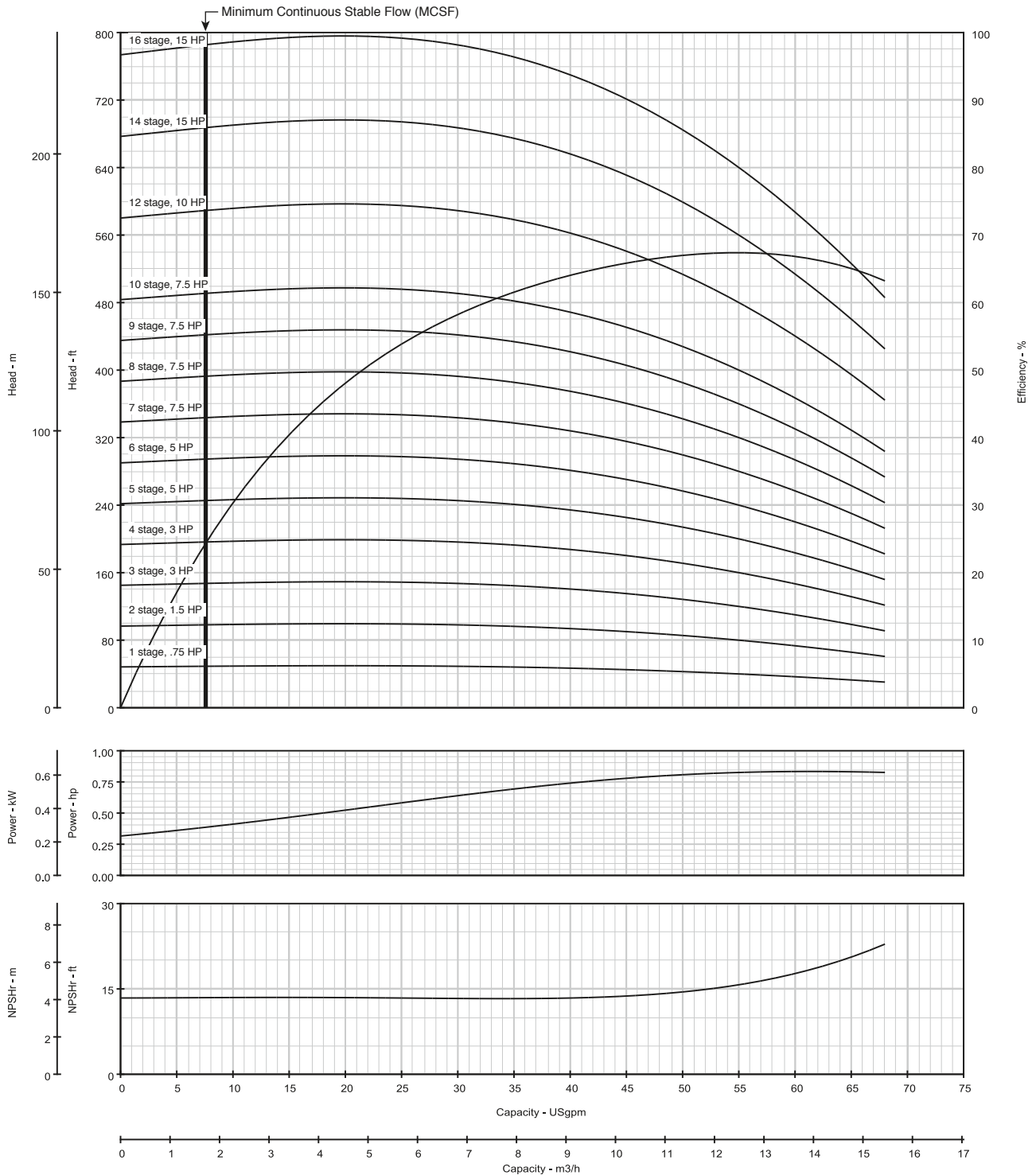

# PVM(X) 15

## VERTICAL MULTISTAGE CENTRIFUGAL PUMPS

### PUMP DIMENSIONS - STANDARD

Model Number	Motor HP	Motor Safety Factor	Phase	Voltage	Motor Frame	PVM Cast Iron								PVMX Stainless Steel							
						Dimensions in inches						Weight in Lbs		Dimensions in inches						Weight in Lbs	
						A	B	C	D	E	F	Pump End Only	Pump & Motor	A	B	C	D	E	F	Pump End Only	Pump & Motor
PVM15-1	2	1.15	1	115V/208-230V	56C	16.3	12.1	7.2	2.1	30.4	7.2	65	118	16.3	12.1	7.2	2.1	30.4	7.2	54	107
PVM15-1	2	1.15	3	208-230V/460V	56C	16.3	12.1	7.2	2.1	30.4	7.2	65	114	16.3	12.1	7.2	2.1	30.4	7.2	54	103
PVM15-2	5	1.15	1	208-230V	213TC	17.0	15.5	9.6	3.1	35.6	9.6	76	193	17.0	15.5	9.6	3.1	35.6	9.6	65	182
PVM15-2	5	1.15	3	208-230V/460V	184TC	17.0	13.9	8.9	2.6	33.6	8.9	76	144	17.0	13.9	8.9	2.6	33.6	8.9	65	133
PVM15-3	7.5	1.15	1	208-230V	213TC	17.4	15.5	8.7	3.1	36.0	8.7	86	203	17.3	15.5	8.7	3.1	35.9	8.7	75	192
PVM15-3	7.5	1.15	3	208-230V/460V	213TC	17.4	15.5	9.6	3.1	36.1	9.6	86	184	17.3	15.5	9.6	3.1	36.0	9.6	75	173
PVM15-4	7.5	1.15	1	208-230V	213TC	20.5	15.5	8.7	3.1	39.1	8.7	96	213	19.1	15.5	8.7	3.1	37.7	8.7	85	202
PVM15-4	7.5	1.15	3	208-230V/460V	213TC	20.5	15.5	9.6	3.1	39.2	9.6	96	194	19.1	15.5	9.6	3.1	37.8	9.6	85	183
PVM15-5	10	1.15	1	208-230V	215TC	22.3	16.6	9.6	3.1	42.0	9.6	106	241	22.2	16.6	9.6	3.1	41.9	9.6	95	230
PVM15-5	10	1.15	3	208-230V/460V	215TC	22.3	15.5	9.6	3.1	41.0	9.6	106	231	22.2	15.5	9.6	3.1	40.9	9.6	95	220
PVM15-6	15	1.15	3	208-230V/460V	254TC	25.9	20.0	12.9	3.8	49.7	12.9	117	392	25.8	20.0	12.9	3.8	49.6	12.9	106	381
PVM15-7	15	1.15	3	208-230V/460V	254TC	27.7	20.0	12.9	3.8	51.5	12.9	127	402	27.6	20.0	12.9	3.8	51.4	12.9	116	391
PVM15-8	15	1.15	3	208-230V/460V	254TC	29.5	20.0	12.9	3.8	53.3	12.9	137	412	29.4	20.0	12.9	3.8	53.2	12.9	126	401
PVM15-9	20	1.15	3	230V/460V	254TC	31.2	16.9	10.3	3.8	51.8	10.3	147	372	31.1	16.9	10.3	3.8	51.7	10.3	136	361
PVM15-10	20	1.15	3	230V/460V	254TC	33.0	16.9	10.3	3.8	53.6	10.3	157	382	32.9	16.9	10.3	3.8	53.5	10.3	146	371
PVM15-12	25	1.15	3	230V/460V	284TSC	38.5	20.0	12.9	3.0	61.5	12.9	177	498	38.4	20.0	12.9	3.0	61.4	12.9	166	487

### PVM

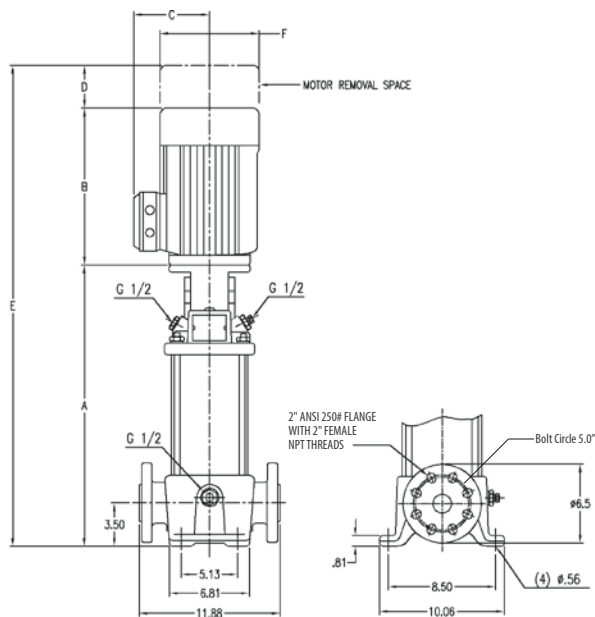

Dual 1-1/4" NPT / 1-1/4" ANSI 250# Flanges

### PVMX

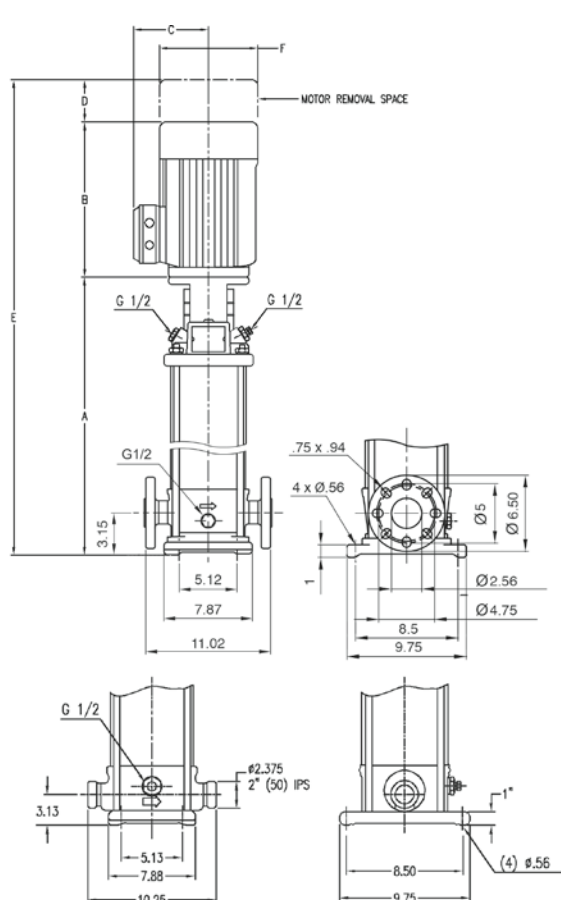

NOTE: G1/2 per ISO-228

# PVM(X) 15

## VERTICAL MULTISTAGE CENTRIFUGAL PUMPS

### PUMP DIMENSIONS - METRIC

Model Number	Motor HP	Motor Safety Factor	Phase	Voltage	Motor Frame	PVM Cast Iron							PVMX Stainless Steel								
						Dimensions in mm						Weight in kgs		Dimensions in mm						Weight in kgs	
						A	B	C	D	E	F	Pump End Only	Pump & Motor	A	B	C	D	E	F	Pump End Only	Pump & Motor
PVM15-1	2	1.15	1	115V/208-230V	56C	414	306	182	52	772	182	29	54	414	306	182	52	772	182	24	48
PVM15-1	2	1.15	3	208-230V/460V	56C	414	306	183	52	772	183	29	52	414	306	183	52	772	183	24	47
PVM15-2	5	1.15	1	208-230V	213TC	432	394	243	79	905	243	34	87	432	394	243	79	905	243	29	82
PVM15-2	5	1.15	3	208-230V/460V	184TC	432	354	225	67	852	225	34	65	432	354	225	67	852	225	29	60
PVM15-3	7.5	1.15	1	208-230V	213TC	442	394	220	79	915	220	39	92	439	394	220	79	912	220	34	87
PVM15-3	7.5	1.15	3	208-230V/460V	213TC	442	395	243	79	916	243	39	83	439	395	243	79	914	243	34	78
PVM15-4	7.5	1.15	1	208-230V	213TC	521	394	220	79	994	220	43	96	485	394	220	79	958	220	38	91
PVM15-4	7.5	1.15	3	208-230V/460V	213TC	521	395	243	79	995	243	43	88	485	395	243	79	959	243	38	83
PVM15-5	10	1.15	1	208-230V	215TC	566	422	243	79	1068	243	48	109	564	422	243	79	1065	243	43	104
PVM15-5	10	1.15	3	208-230V/460V	215TC	566	394	243	79	1040	243	48	105	564	394	243	79	1038	243	43	100
PVM15-6	15	1.15	3	208-230V/460V	254TC	658	509	329	95	1262	329	53	178	655	509	329	95	1259	329	48	173
PVM15-7	15	1.15	3	208-230V/460V	254TC	704	509	329	95	1308	329	58	182	701	509	329	95	1305	329	53	177
PVM15-8	15	1.15	3	208-230V/460V	254TC	749	509	329	95	1353	329	62	187	747	509	329	95	1351	329	57	182
PVM15-9	20	1.15	3	230V/460V	254TC	792	428	263	95	1316	263	67	169	790	428	263	95	1313	263	62	164
PVM15-10	20	1.15	3	230V/460V	254TC	838	428	263	95	1362	263	71	173	836	428	263	95	1359	263	66	168
PVM15-12	25	1.15	3	230V/460V	284TSC	978	507	329	76	1561	329	80	226	975	507	329	76	1559	329	75	221

PVM

PVMX

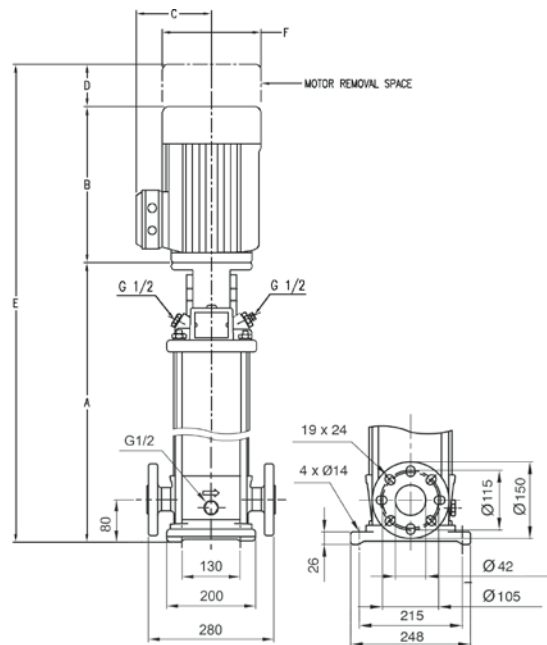
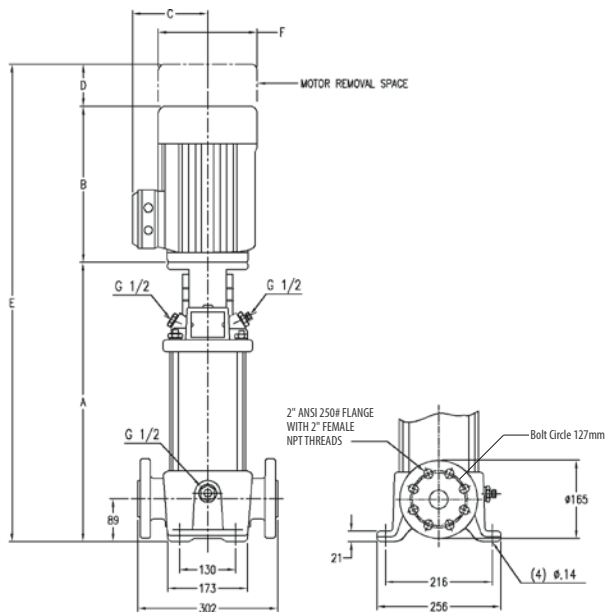

Dual 2" NPT/ 2" ANSI 250# Flanges

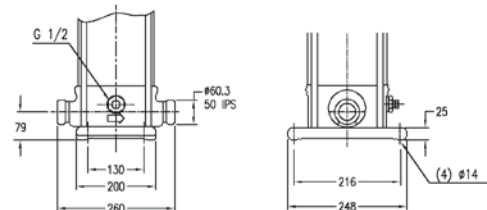

NOTE: G1/2 per ISO-228

# PVM(X) 15

## VERTICAL MULTISTAGE CENTRIFUGAL PUMPS

### HYDRAULIC PERFORMANCE

Curve PVM(X) 15  
Date 10/01/14

Nominal rpm: 3500  
Based on fresh water @ 68° F  
Maximum working pressure: 360 psi

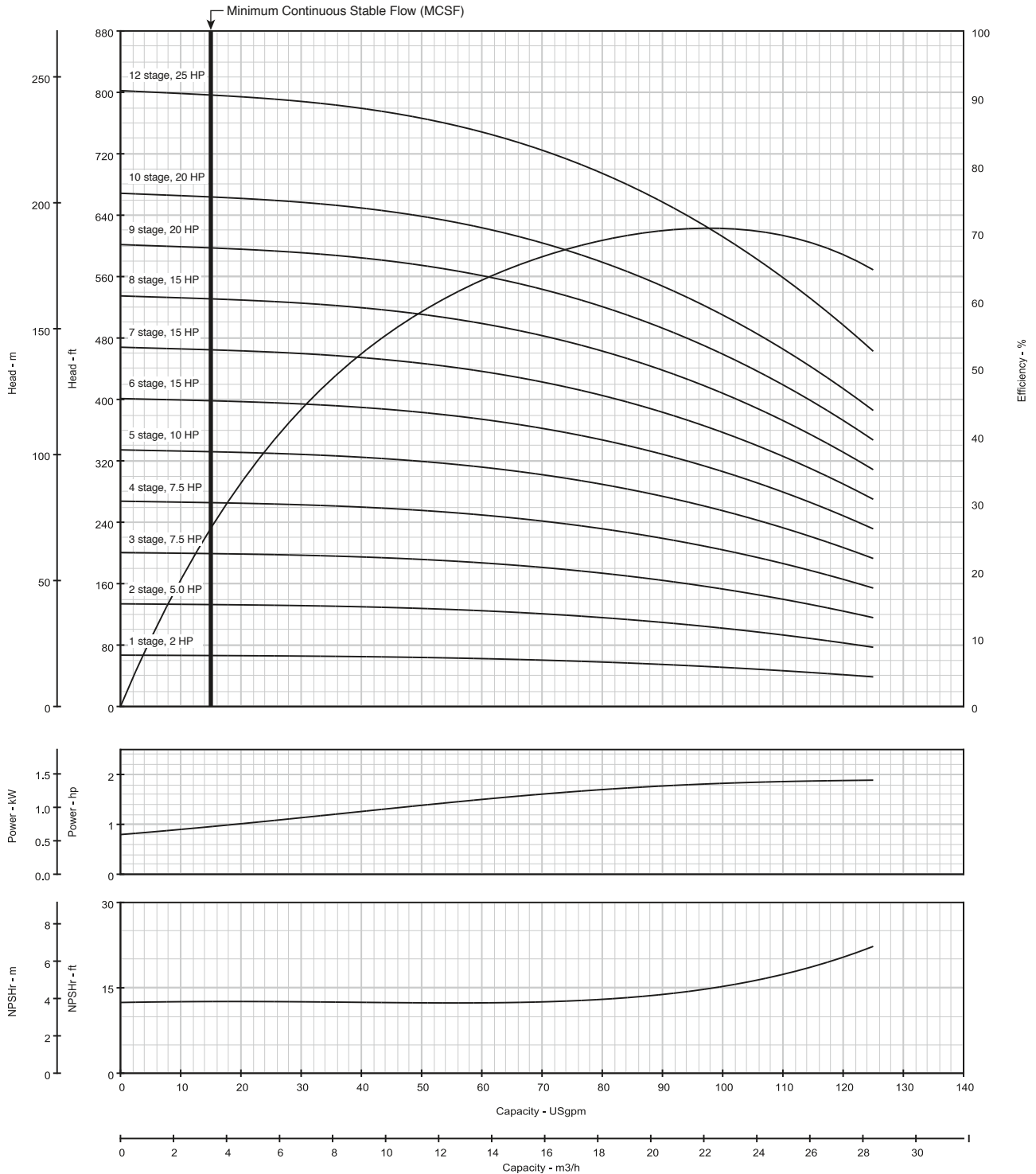

# PVM(X) 20

## VERTICAL MULTISTAGE CENTRIFUGAL PUMPS

### PUMP DIMENSIONS – STANDARD

Model Number	Motor HP	Motor Service Factor	Phase	Voltage	Motor Frame	PVM Cast Iron								PVMX Stainless Steel							
						Dimensions in inches						Weight in Lbs		Dimensions in inches						Weight in Lbs	
						A	B	C	D	E	F	Pump End Only	Pump & Motor	A	B	C	D	E	F	Pump End Only	Pump & Motor
PVM20-1	3	1.15	1	115V/208-230V	182TC	16.8	15.4	8.9	2.6	34.8	8.9	66	154	16.8	15.4	8.7	2.6	34.8	8.7	55	143
PVM20-1	3	1.15	3	208-230V/460V	182TC	16.8	13.9	8.9	2.6	33.4	8.9	66	134	16.8	13.9	8.7	2.6	33.4	8.7	55	123
PVM20-2	5	1.15	1	208-230V	213TC	17.0	15.5	9.6	3.1	35.6	9.6	76	193	17.0	15.5	9.6	3.1	35.6	9.6	65	182
PVM20-2	5	1.15	3	208-230V/460V	184TC	17.0	13.9	8.9	2.6	33.6	8.9	76	144	17.0	13.9	8.9	2.6	33.6	8.9	65	133
PVM20-3	7.5	1.15	1	208-230V	213TC	18.8	15.5	8.7	3.1	37.4	8.7	86	203	18.8	15.5	8.7	3.1	37.4	8.7	75	192
PVM20-3	7.5	1.15	3	208-230V/460V	213TC	18.8	15.5	9.6	3.1	37.5	9.6	86	184	18.8	15.5	9.6	3.1	37.5	9.6	75	173
PVM20-4	10	1.15	1	208-230V	215TC	20.5	16.6	9.6	3.1	40.2	9.6	96	231	20.5	16.6	9.6	3.1	40.2	9.6	85	220
PVM20-4	10	1.15	3	208-230V/460V	215TC	20.5	15.5	9.6	3.1	39.2	9.6	96	221	20.5	15.5	9.6	3.1	39.2	9.6	85	210
PVM20-5	15	1.15	3	208-230V/460V	254TC	24.1	20.0	12.9	3.8	47.9	12.9	107	382	24.1	20.0	12.9	3.8	47.9	12.9	96	371
PVM20-6	15	1.15	3	208-230V/460V	254TC	25.9	20.0	12.9	3.8	49.7	12.9	117	392	25.9	20.0	12.9	3.8	49.7	12.9	106	381
PVM20-7	20	1.15	3	230V/460V	254TC	27.7	16.9	10.3	3.8	48.3	10.3	127	352	27.7	16.9	10.3	3.8	48.3	10.3	116	341
PVM20-8	20	1.15	3	230V/460V	254TC	29.5	16.9	10.3	3.8	50.1	10.3	137	362	29.5	16.9	10.3	3.8	50.1	10.3	126	351
PVM20-10	25	1.15	3	230V/460V	284TSC	35.0	20.0	12.9	3.0	58.0	12.9	157	478	35.0	20.0	12.9	3.0	58.0	12.9	146	467

PVM

PVMX

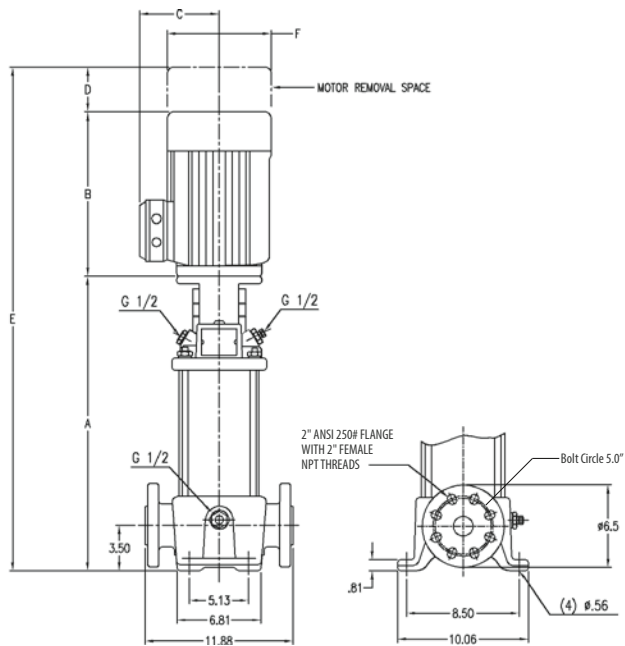

Dual 2" NPT/ 2" ANSI 250# Flanges

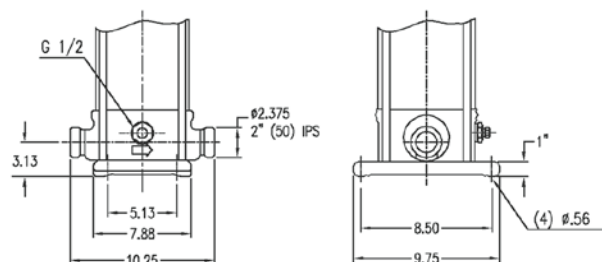
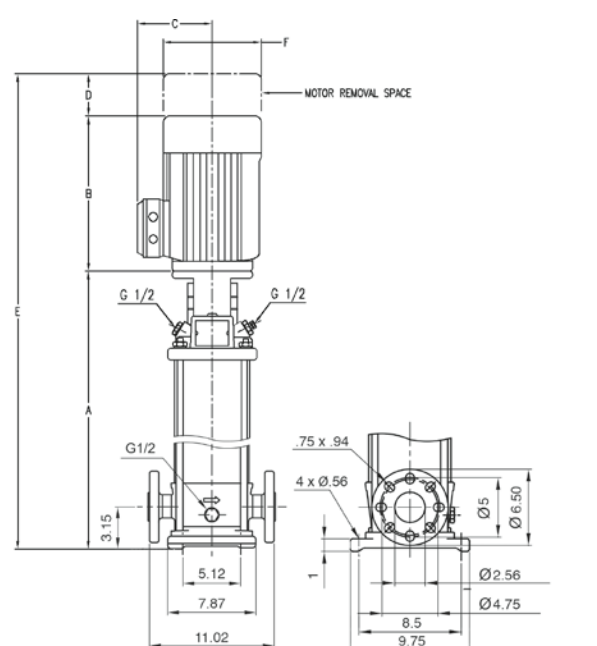

NOTE: G1/2 per ISO-228

# PVM(X) 20

## VERTICAL MULTISTAGE CENTRIFUGAL PUMPS

### PUMP DIMENSIONS - METRIC

Model Number	Motor HP	Motor Safety Factor	Phase	Voltage	Motor Frame	PVM Cast Iron							PVMX Stainless Steel								
						Dimensions in mm						Weight in kgs		Dimensions in mm						Weight in kgs	
						A	B	C	D	E	F	Pump End Only	Pump & Motor	A	B	C	D	E	F	Pump End Only	Pump & Motor
PVM20-1	3	1.15	1	115V/208-230V	182TC	427	392	225	67	885	225	30	70	427	392	220	67	885	220	25	65
PVM20-1	3	1.15	3	208-230V/460V	182TC	427	354	225	67	847	225	30	61	427	354	220	67	847	220	25	56
PVM20-2	5	1.15	1	208-230V	213TC	432	394	243	79	905	243	34	87	432	394	243	79	905	243	29	82
PVM20-2	5	1.15	3	208-230V/460V	184TC	432	354	225	67	852	225	34	65	432	354	225	67	852	225	29	60
PVM20-3	7.5	1.15	1	208-230V	213TC	478	394	220	79	951	220	39	92	478	394	220	79	951	220	34	87
PVM20-3	7.5	1.15	3	208-230V/460V	213TC	478	395	243	79	952	243	39	83	478	395	243	79	952	243	34	78
PVM20-4	10	1.15	1	208-230V	215TC	521	422	243	79	1022	243	43	105	521	422	243	79	1022	243	38	100
PVM20-4	10	1.15	3	208-230V/460V	215TC	521	394	243	79	995	243	43	100	521	394	243	79	995	243	38	95
PVM20-5	15	1.15	3	208-230V/460V	254TC	612	509	329	95	1216	329	49	173	612	509	329	95	1216	329	43	168
PVM20-6	15	1.15	3	208-230V/460V	254TC	658	509	329	95	1262	329	53	178	658	509	329	95	1262	329	48	173
PVM20-7	20	1.15	3	230V/460V	254TC	704	428	263	95	1227	263	58	160	704	428	263	95	1227	263	53	155
PVM20-8	20	1.15	3	230V/460V	254TC	749	428	263	95	1273	263	62	164	749	428	263	95	1273	263	57	159
PVM20-10	25	1.15	3	230V/460V	284TSC	889	507	329	76	1472	329	71	217	889	507	329	76	1472	329	66	212

### PVM

### PVMX

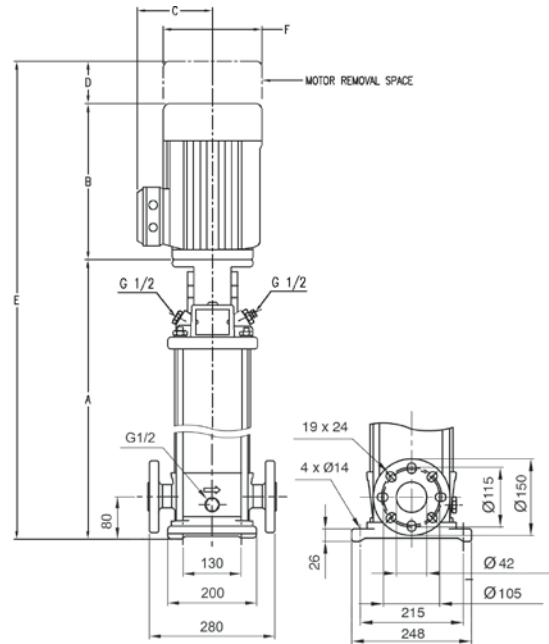
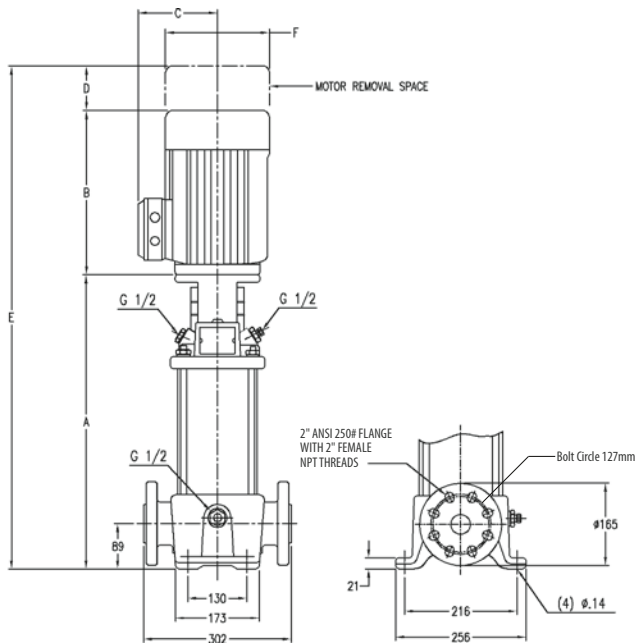

Dual 2" NPT / 2" ANSI 250# Flanges

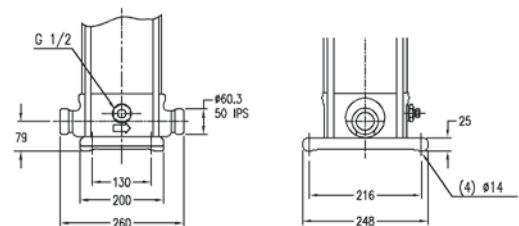

NOTE: G1/2 per ISO-228

# PVM(X) 20

## VERTICAL MULTISTAGE CENTRIFUGAL PUMPS

### HYDRAULIC PERFORMANCE

Curve PVM(X) 20  
Date 10/01/14

Nominal rpm: 3500  
Based on fresh water @ 68°F  
Maximum working pressure: 360 psi

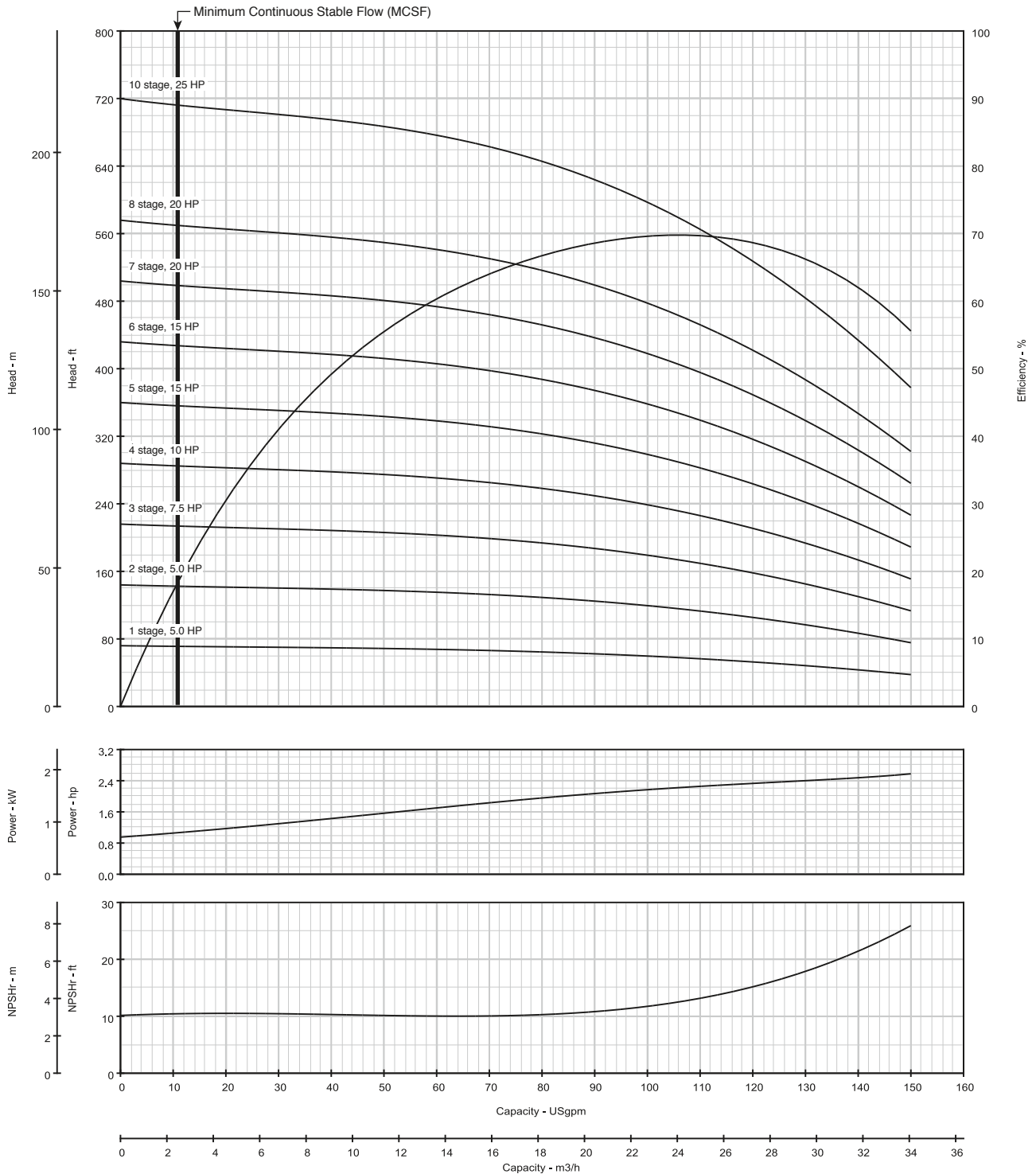

# PVM(X) 33

## VERTICAL MULTISTAGE CENTRIFUGAL PUMPS

### PUMP DIMENSIONS – STANDARD

Model Number	Motor HP	Motor Service Factor	Phase	Voltage	Motor Frame	PVM Cast Iron								PVMX Stainless Steel							
						Dimensions in inches						Weight in Lbs		Dimensions in inches						Weight in Lbs	
						A	B	C	D	E	F	Pump End Only	Pump & Motor	A	B	C	D	E	F	Pump End Only	Pump & Motor
PVM33-1-1	5	1.15	1	208-230V	213TC	20.3	15.5	9.6	3.1	38.9	9.6	130	247	20.3	15.5	9.6	3.1	38.9	9.6	130	247
PVM33-1-1	5	1.15	3	208-230V/460V	184TC	20.3	13.9	8.9	2.6	36.9	8.9	130	198	20.3	13.9	8.9	2.6	36.9	8.9	130	198
PVM33-1	5	1.15	1	208-230V	213TC	20.3	15.5	9.6	3.1	38.9	9.6	130	247	20.3	15.5	9.6	3.1	38.9	9.6	130	247
PVM33-1	5	1.15	3	208-230V/460V	184TC	20.3	13.9	8.9	2.6	36.9	8.9	130	198	20.3	13.9	8.9	2.6	36.9	8.9	130	198
PVM33-2-2	7.5	1.15	1	208-230V	213TC	21.8	15.5	8.7	3.1	40.4	8.7	132	249	21.8	15.5	8.7	3.1	40.4	8.7	132	249
PVM33-2-2	7.5	1.15	3	208-230V/460V	213TC	21.8	15.5	9.6	3.1	40.5	9.6	132	230	21.8	15.5	9.6	3.1	40.5	9.6	132	230
PVM33-2-1	7.5	1.15	1	208-230V	213TC	21.8	15.5	8.7	3.1	40.4	8.7	132	249	21.8	15.5	8.7	3.1	40.4	8.7	132	249
PVM33-2-1	7.5	1.15	3	208-230V/460V	213TC	21.8	15.5	9.6	3.1	40.5	9.6	132	230	21.8	15.5	9.6	3.1	40.5	9.6	132	230
PVM33-2	10	1.15	1	208-230V	215TC	21.8	16.6	9.6	3.1	41.5	9.6	132	267	21.8	16.6	9.6	3.1	41.5	9.6	132	267
PVM33-2	10	1.15	3	208-230V/460V	215TC	21.8	15.5	9.6	3.1	40.5	9.6	132	257	21.8	15.5	9.6	3.1	40.5	9.6	132	257
PVM33-3-2	10	1.15	1	208-230V	215TC	28.9	16.6	9.6	3.1	48.6	9.6	132	267	28.9	16.6	9.6	3.1	48.6	9.6	132	267
PVM33-3-2	10	1.15	3	208-230V/460V	215TC	28.9	15.5	9.6	3.1	47.6	9.6	132	257	28.9	15.5	9.6	3.1	47.6	9.6	132	257
PVM33-3	15	1.15	3	208-230V/460V	254TC	27.7	20.0	12.9	3.8	51.5	12.9	138	413	27.7	20.0	12.9	3.8	51.5	12.9	138	413
PVM33-4-2	15	1.15	3	208-230V/460V	254TC	30.4	20.0	12.9	3.8	54.2	12.9	138	413	30.4	20.0	12.9	3.8	54.2	12.9	138	413
PVM33-4	20	1.15	3	230V/460V	254TC	30.4	16.9	10.3	3.8	51.0	10.3	148	373	30.4	16.9	10.3	3.8	51.0	10.3	148	373
PVM33-5-2	20	1.15	3	230V/460V	254TC	33.2	16.9	10.3	3.8	53.8	10.3	162	387	33.2	16.9	10.3	3.8	53.8	10.3	162	387
PVM33-5	20	1.15	3	230V/460V	254TC	33.2	16.9	10.3	3.8	53.8	10.3	162	387	33.2	16.9	10.3	3.8	53.8	10.3	162	387
PVM33-6-2	25	1.15	3	230V/460V	284TSC	38.0	20.0	12.9	3.0	61.0	12.9	180	501	38.0	20.0	12.9	3.0	61.0	12.9	180	501
PVM33-6	25	1.15	3	230V/460V	284TSC	38.0	20.0	12.9	3.0	61.0	12.9	180	501	38.0	20.0	12.9	3.0	61.0	12.9	180	501
PVM33-7-2	30	1.15	3	230V/460V	284TSC	40.7	23.2	15.6	3.0	66.9	15.6	202	625	40.7	23.2	15.6	3.0	66.9	15.6	202	625
PVM33-7	30	1.15	3	230V/460V	284TSC	40.7	23.2	15.6	3.0	66.9	15.6	202	625	40.7	23.2	15.6	3.0	66.9	15.6	202	625
PVM33-8-2	30	1.15	3	230V/460V	284TSC	43.5	23.2	15.6	3.0	69.7	15.6	228	651	43.5	23.2	15.6	3.0	69.7	15.6	228	651
PVM33-8	40	1.15	3	230V/460V	286TSC	43.5	23.2	15.6	3.0	69.7	15.6	228	708	43.5	23.2	15.6	3.0	69.7	15.6	228	708
PVM33-9-2	40	1.15	3	230V/460V	286TSC	46.2	23.2	15.6	3.0	72.4	15.6	258	738	46.2	23.2	15.6	3.0	72.4	15.6	258	738
PVM33-9	40	1.15	3	230V/460V	286TSC	46.2	23.2	15.6	3.0	72.4	15.6	258	738	46.2	23.2	15.6	3.0	72.4	15.6	258	738
PVM33-10-2	40	1.15	3	230V/460V	286TSC	49.0	23.2	15.6	3.0	75.2	15.6	292	772	49.0	23.2	15.6	3.0	75.2	15.6	292	772

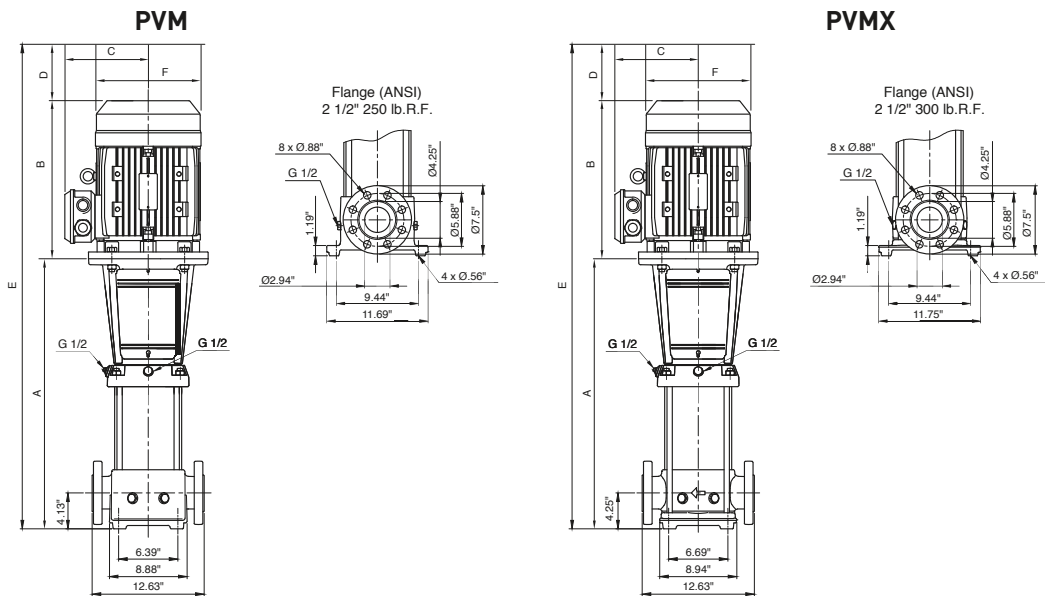

NOTE: G1/2 per ISO-228

# PVM(X) 33

## VERTICAL MULTISTAGE CENTRIFUGAL PUMPS

### PUMP DIMENSIONS - METRIC

Model Number	Motor HP	Motor Safety Factor	Phase	Voltage	Motor Frame	PVM Cast Iron							PVMX Stainless Steel								
						Dimensions in mm						Weight in kgs		Dimensions in mm						Weight in kgs	
						A	B	C	D	E	F	Pump End Only	Pump & Motor	A	B	C	D	E	F	Pump End Only	Pump & Motor
PVM33-1-1	5	1.15	1	208-230V	213TC	516	394	243	79	989	243	59	112	516	394	243	79	989	243	59	112
PVM33-1-1	5	1.15	3	208-230V/460V	184TC	516	354	225	67	936	225	59	90	516	354	225	67	936	225	59	90
PVM33-1	5	1.15	1	208-230V	213TC	516	394	243	79	989	243	59	112	516	394	243	79	989	243	59	112
PVM33-1	5	1.15	3	208-230V/460V	184TC	516	354	225	67	936	225	59	90	516	354	225	67	936	225	59	90
PVM33-2-2	7.5	1.15	1	208-230V	213TC	554	394	220	79	1027	220	60	113	554	394	220	79	1027	220	60	113
PVM33-2-2	7.5	1.15	3	208-230V/460V	213TC	554	395	243	79	1028	243	60	104	554	395	243	79	1028	243	60	104
PVM33-2-1	7.5	1.15	1	208-230V	213TC	554	394	220	79	1027	220	60	113	554	394	220	79	1027	220	60	113
PVM33-2-1	7.5	1.15	3	208-230V/460V	213TC	554	395	243	79	1028	243	60	104	554	395	243	79	1028	243	60	104
PVM33-2	10	1.15	1	208-230V	215TC	554	422	243	79	1055	243	60	121	554	422	243	79	1055	243	60	121
PVM33-2	10	1.15	3	208-230V/460V	215TC	554	394	243	79	1028	243	60	117	554	394	243	79	1028	243	60	117
PVM33-3-2	10	1.15	1	208-230V	215TC	734	422	243	79	1236	243	60	121	734	422	243	79	1236	243	60	121
PVM33-3-2	10	1.15	3	208-230V/460V	215TC	734	394	243	79	1208	243	60	117	734	394	243	79	1208	243	60	117
PVM33-3	15	1.15	3	208-230V/460V	254TC	704	509	329	95	1308	329	63	187	704	509	329	95	1308	329	63	187
PVM33-4-2	15	1.15	3	208-230V/460V	254TC	772	509	329	95	1376	329	63	187	772	509	329	95	1376	329	63	187
PVM33-4	20	1.15	3	230V/460V	254TC	772	428	263	95	1296	263	67	169	772	428	263	95	1296	263	67	169
PVM33-5-2	20	1.15	3	230V/460V	254TC	843	428	263	95	1367	263	73	176	843	428	263	95	1367	263	73	176
PVM33-5	20	1.15	3	230V/460V	254TC	843	428	263	95	1367	263	73	176	843	428	263	95	1367	263	73	176
PVM33-6-2	25	1.15	3	230V/460V	284TSC	965	507	329	76	1549	329	82	227	965	507	329	76	1549	329	82	227
PVM33-6	25	1.15	3	230V/460V	284TSC	965	507	329	76	1549	329	82	227	965	507	329	76	1549	329	82	227
PVM33-7-2	30	1.15	3	230V/460V	284TSC	1034	589	395	76	1699	395	92	283	1034	589	395	76	1699	395	92	283
PVM33-7	30	1.15	3	230V/460V	284TSC	1034	589	395	76	1699	395	92	283	1034	589	395	76	1699	395	92	283
PVM33-8-2	30	1.15	3	230V/460V	284TSC	1105	589	395	76	1770	395	103	295	1105	589	395	76	1770	395	103	295
PVM33-8	40	1.15	3	230V/460V	286TSC	1105	589	395	76	1770	395	103	321	1105	589	395	76	1770	395	103	321
PVM33-9-2	40	1.15	3	230V/460V	286TSC	1173	589	395	76	1839	395	117	335	1173	589	395	76	1839	395	117	335
PVM33-9	40	1.15	3	230V/460V	286TSC	1173	589	395	76	1839	395	117	335	1173	589	395	76	1839	395	117	335
PVM33-10-2	40	1.15	3	230V/460V	286TSC	1245	589	395	76	1910	395	132	350	1245	589	395	76	1910	395	132	350

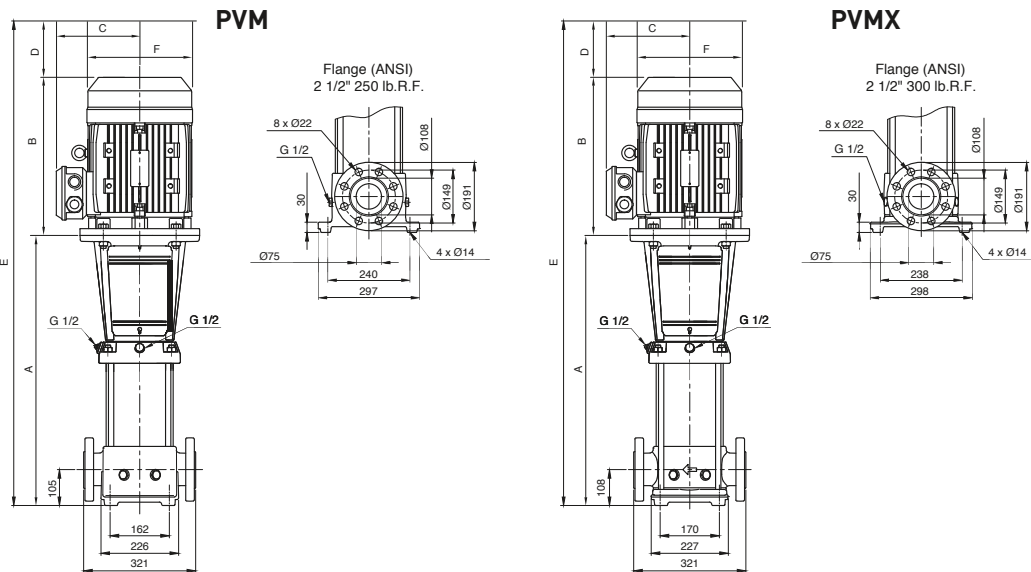

NOTE: G1/2 per ISO-228

# PVM(X) 33

## VERTICAL MULTISTAGE CENTRIFUGAL PUMPS

### HYDRAULIC PERFORMANCE

Curve PVM(X) 33  
Date 10/01/14

Nominal rpm: 3500  
Based on fresh water @ 68° F  
Maximum working pressure: 435 psi

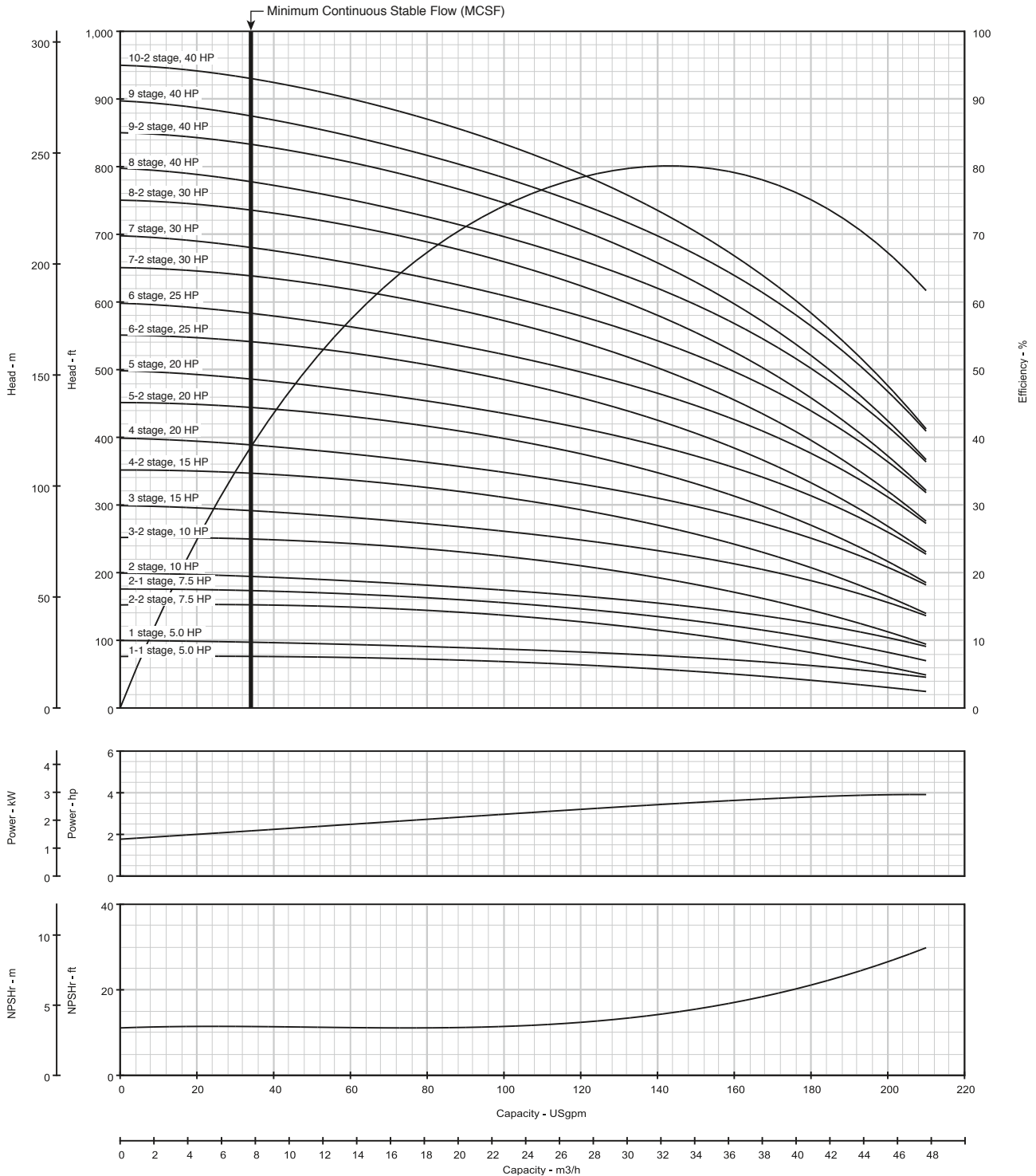

# PVM(X) 45

## VERTICAL MULTISTAGE CENTRIFUGAL PUMPS

### PUMP DIMENSIONS – STANDARD

Model Number	Motor HP	Motor Service Factor	Phase	Voltage	Motor Frame	PVM Cast Iron								PVMX Stainless Steel							
						Dimensions in inches						Weight in Lbs		Dimensions in inches						Weight in Lbs	
						A	B	C	D	E	F	Pump End Only	Pump & Motor	A	B	C	D	E	F	Pump End Only	Pump & Motor
PVM45-1-1	7.5	1.15	1	208-230V	213TC	21.3	15.5	8.7	3.1	39.9	8.7	143	260	21.2	15.5	8.7	3.1	39.8	8.7	124	241
PVM45-1-1	7.5	1.15	3	208-230V/460V	213TC	21.3	15.5	9.6	3.1	40.0	9.6	143	241	21.2	15.5	9.6	3.1	39.9	9.6	124	222
PVM45-1	10	1.15	1	208-230V	215TC	21.3	16.6	9.6	3.1	41.0	9.6	143	278	21.2	16.6	9.6	3.1	40.9	9.6	124	259
PVM45-1	10	1.15	3	208-230V/460V	215TC	21.3	15.5	9.6	3.1	40.0	9.6	143	268	21.2	15.5	9.6	3.1	39.9	9.6	124	249
PVM45-2-2	15	1.15	3	208-230V/460V	254TC	27.6	20.0	12.9	3.8	51.4	12.9	172	447	27.5	20.0	12.9	3.8	51.3	12.9	154	429
PVM45-2-1	15	1.15	3	208-230V/460V	254TC	27.6	20.0	12.9	3.8	51.4	12.9	172	447	27.5	20.0	12.9	3.8	51.3	12.9	154	429
PVM45-2	15	1.15	3	230V/460V	254TC	30.4	16.9	10.3	3.8	51.0	10.3	172	397	27.5	16.9	10.3	3.8	48.1	10.3	154	379
PVM45-3-2	20	1.15	3	230V/460V	254TC	32.7	20.0	12.9	3.8	56.4	12.9	180	501	32.6	20.0	12.9	3.8	56.3	12.9	162	483
PVM45-3-1	25	1.15	3	230V/460V	284TSC	32.7	20.0	12.9	3.0	55.7	12.9	183	504	32.6	20.0	12.9	3.0	55.6	12.9	164	485
PVM45-3	25	1.15	3	230V/460V	284TSC	32.7	20.0	12.9	3.0	55.7	12.9	183	504	32.6	20.0	12.9	3.0	55.6	12.9	164	485
PVM45-4-2	30	1.15	3	230V/460V	284TSC	35.9	23.2	15.6	3.0	62.1	15.6	191	614	35.8	23.2	15.6	3.0	62.0	15.6	172	595
PVM45-4-1	30	1.15	3	230V/460V	284TSC	35.9	23.2	15.6	3.0	62.1	15.6	191	614	35.8	23.2	15.6	3.0	62.0	15.6	172	595
PVM45-4	30	1.15	3	230V/460V	284TSC	35.9	23.2	15.6	3.0	62.1	15.6	191	614	35.8	23.2	15.6	3.0	62.0	15.6	172	595
PVM45-5-2	40	1.15	3	230V/460V	286TSC	39.0	23.2	15.6	3.0	65.2	15.6	199	679	38.9	23.2	15.6	3.0	65.1	15.6	180	660
PVM45-5-1	40	1.15	3	230V/460V	286TSC	39.0	23.2	15.6	3.0	65.2	15.6	199	679	38.9	23.2	15.6	3.0	65.1	15.6	180	660
PVM45-5	40	1.15	3	230V/460V	286TSC	39.0	23.2	15.6	3.0	65.2	15.6	199	679	38.9	23.2	15.6	3.0	65.1	15.6	180	660
PVM45-6-2	50	1.15	3 (TEFC)	230V/460V	326TSC	42.2	28.8	16.5	3.5	74.5	16.5	224	724	42.1	28.8	16.5	3.5	74.4	16.5	205	705
PVM45-6-2	50	1.15	3 (ODP)	230V/460V	324TSC	42.2	25.7	16.5	3.5	71.4	16.5	224	603	42.1	25.7	16.5	3.5	71.3	16.5	206	585
PVM45-6	50	1.15	3 (TEFC)	230V/460V	326TSC	42.2	28.8	16.5	3.5	74.5	16.5	232	732	42.1	28.8	16.5	3.5	74.4	16.5	206	706
PVM45-6	50	1.15	3 (ODP)	230V/460V	324TSC	42.2	25.7	16.5	3.5	71.4	16.5	232	611	42.1	25.7	16.5	3.5	71.3	16.5	206	585
PVM45-7-2	50	1.15	3 (TEFC)	230V/460V	326TSC	45.3	28.8	16.5	3.5	77.6	16.5	232	732	45.2	28.8	16.5	3.5	77.5	16.5	214	714
PVM45-7-2	50	1.15	3 (ODP)	230V/460V	324TSC	45.3	25.7	16.5	3.5	74.5	16.5	232	611	45.2	25.7	16.5	3.5	74.4	16.5	214	593
PVM45-7	60	1.15	3 (TEFC)	230V/460V	364TSC	45.3	31.4	18.5	3.5	80.2	18.5	232	916	45.2	31.4	18.5	3.5	80.1	18.5	214	898
PVM45-7	60	1.15	3 (ODP)	230V/460V	324TSC	45.3	25.7	18.5	3.5	74.5	18.5	232	621	45.2	25.7	18.5	3.5	74.4	18.5	214	603
PVM45-8-2	60	1.15	3 (TEFC)	230V/460V	364TSC	48.4	31.4	18.5	3.5	83.3	18.5	232	916	48.3	31.4	18.5	3.5	83.2	18.5	222	906
PVM45-8-2	60	1.15	3 (ODP)	230V/460V	324TSC	48.4	25.7	18.5	3.5	77.6	18.5	232	621	48.3	25.7	18.5	3.5	77.5	18.5	222	611

# PVM(X) 45

## VERTICAL MULTISTAGE CENTRIFUGAL PUMPS

### PUMP DIMENSIONS – STANDARD

**PVM**

**PVMX**

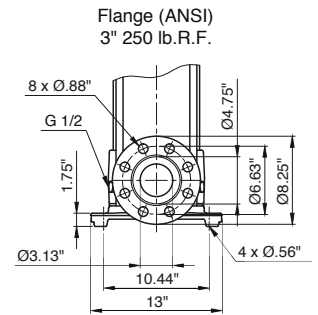
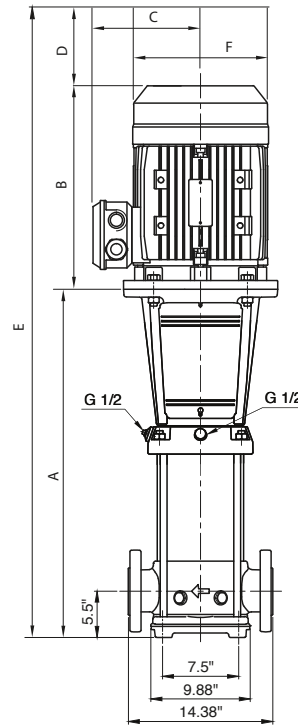
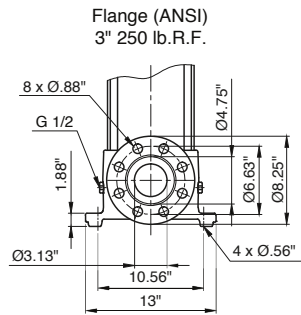
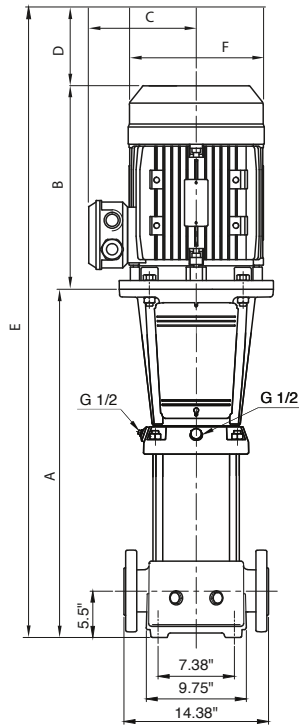

NOTE: G1/2 per ISO-228

# PVM(X) 45

## VERTICAL MULTISTAGE CENTRIFUGAL PUMPS

### PUMP DIMENSIONS – METRIC

Model Number	Motor HP	Motor Service Factor	Phase	Voltage	Motor Frame	PVM Cast Iron							PVMX Stainless Steel								
						Dimensions in mm						Weight in kgs		Dimensions in mm						Weight in kgs	
						A	B	C	D	E	F	Pump End Only	Pump & Motor	A	B	C	D	E	F	Pump End Only	Pump & Motor
PVM45-1-1	7.5	1.15	1	208-230V	213TC	541	394	220	79	1014	220	65	118	538	394	220	79	1012	220	56	109
PVM45-1-1	7.5	1.15	3	208-230V/460V	213TC	541	395	243	79	1015	243	65	109	538	395	243	79	1013	243	56	101
PVM45-1	10	1.15	1	208-230V	215TC	541	422	243	79	1043	243	65	126	538	422	243	79	1040	243	56	117
PVM45-1	10	1.15	3	208-230V/460V	215TC	541	394	243	79	1015	243	65	122	538	394	243	79	1012	243	56	113
PVM45-2-2	15	1.15	3	208-230V/460V	254TC	701	509	329	95	1305	329	78	203	699	509	329	95	1303	329	70	195
PVM45-2-1	15	1.15	3	208-230V/460V	254TC	701	509	329	95	1305	329	78	203	699	509	329	95	1303	329	70	195
PVM45-2	15	1.15	3	230V/460V	254TC	772	428	263	95	1296	263	78	180	699	428	263	95	1222	263	70	172
PVM45-3-2	20	1.15	3	230V/460V	254TC	831	507	329	95	1433	329	82	227	828	507	329	95	1431	329	73	219
PVM45-3-1	25	1.15	3	230V/460V	284TSC	831	507	329	76	1414	329	83	229	828	507	329	76	1411	329	74	220
PVM45-3	25	1.15	3	230V/460V	284TSC	831	507	329	76	1414	329	83	229	828	507	329	76	1411	329	74	220
PVM45-4-2	30	1.15	3	230V/460V	284TSC	912	589	395	76	1577	395	87	278	909	589	395	76	1575	395	78	270
PVM45-4-1	30	1.15	3	230V/460V	284TSC	912	589	395	76	1577	395	87	278	909	589	395	76	1575	395	78	270
PVM45-4	30	1.15	3	230V/460V	284TSC	912	589	395	76	1577	395	87	278	909	589	395	76	1575	395	78	270
PVM45-5-2	40	1.15	3	230V/460V	286TSC	991	589	395	76	1656	395	90	308	988	589	395	76	1653	395	82	299
PVM45-5-1	40	1.15	3	230V/460V	286TSC	991	589	395	76	1656	395	90	308	988	589	395	76	1653	395	82	299
PVM45-5	40	1.15	3	230V/460V	286TSC	991	589	395	76	1656	395	90	308	988	589	395	76	1653	395	82	299
PVM45-6-2	50	1.15	3 (TEFC)	230V/460V	326TSC	1072	731	419	89	1892	419	102	328	1069	731	419	89	1889	419	93	320
PVM45-6-2	50	1.15	3 (ODP)	230V/460V	324TSC	1072	653	419	89	1813	419	102	273	1069	653	419	89	1811	419	93	265
PVM45-6	50	1.15	3 (TEFC)	230V/460V	326TSC	1072	731	419	89	1892	419	105	332	1069	731	419	89	1889	419	93	320
PVM45-6	50	1.15	3 (ODP)	230V/460V	324TSC	1072	653	419	89	1813	419	105	277	1069	653	419	89	1811	419	93	265
PVM45-7-2	50	1.15	3 (TEFC)	230V/460V	326TSC	1151	731	419	89	1971	419	105	332	1148	731	419	89	1968	419	97	324
PVM45-7-2	50	1.15	3 (ODP)	230V/460V	324TSC	1151	653	419	89	1892	419	105	277	1148	653	419	89	1890	419	97	269
PVM45-7	60	1.15	3 (TEFC)	230V/460V	364TSC	1151	797	470	89	2036	470	105	415	1148	797	470	89	2034	470	97	407
PVM45-7	60	1.15	3 (ODP)	230V/460V	324TSC	1151	653	470	89	1892	470	105	282	1148	653	470	89	1890	470	97	273
PVM45-8-2	60	1.15	3 (TEFC)	230V/460V	364TSC	1229	797	470	89	2115	470	105	415	1227	797	470	89	2112	470	101	411
PVM45-8-2	60	1.15	3 (ODP)	230V/460V	324TSC	1229	653	470	89	1971	470	105	282	1227	653	470	89	1968	470	101	277

# PVM(X) 45

## VERTICAL MULTISTAGE CENTRIFUGAL PUMPS

### PUMP DIMENSIONS - METRIC

**PVM**

**PVMX**

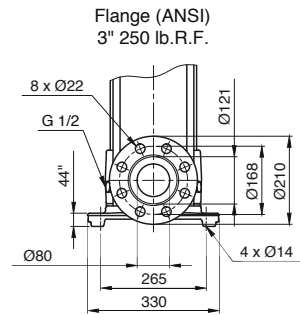
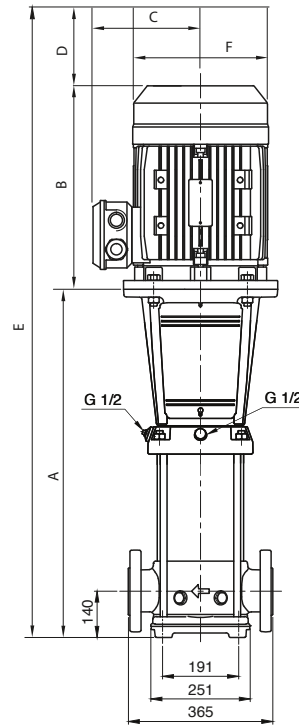
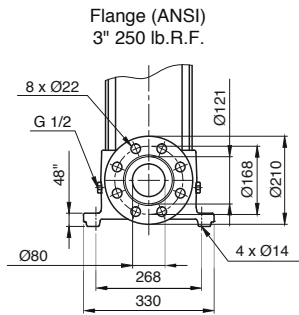
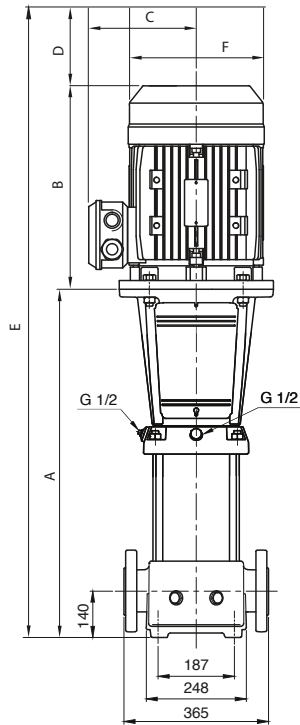

NOTE: G1/2 per ISO-228

# PVM(X) 45

## VERTICAL MULTISTAGE CENTRIFUGAL PUMPS

### HYDRAULIC PERFORMANCE

Curve PVM(X) 45  
Date 10/01/14

Nominal rpm: 3500  
Based on fresh water @ 68° F  
Maximum working pressure: 435 psi

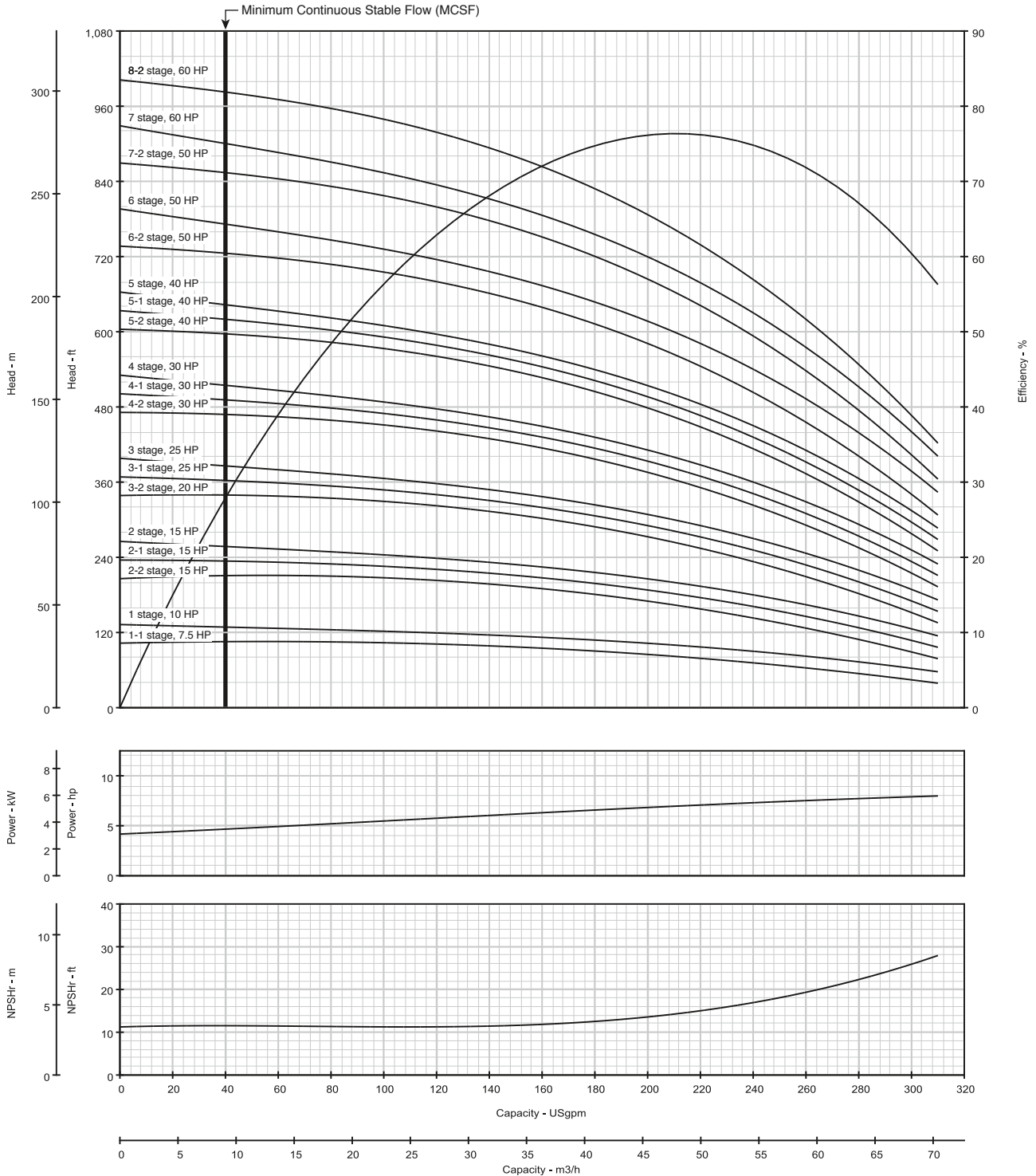

# PVM(X) 64

## VERTICAL MULTISTAGE CENTRIFUGAL PUMPS

### PUMP DIMENSIONS - STANDARD

Model Number	Motor HP	Motor Safety Factor	Phase	Voltage	Motor Frame	PVM Cast Iron								PVMX Stainless Steel							
						Dimensions in inches						Weight in Lbs		Dimensions in inches						Weight in Lbs	
						A	B	C	D	E	F	Pump End Only	Pump & Motor	A	B	C	D	E	F	Pump End Only	Pump & Motor
PVM64-1-1	10	1.15	1	208-230V	215TC	21.4	16.6	9.6	3.1	41.1	9.6	130	265	21.4	16.6	9.6	3.1	41.1	9.6	115	250
PVM64-1-1	10	1.15	3	208-230V/460V	215TC	21.4	15.5	9.6	3.1	40.1	9.6	130	255	21.4	15.5	9.6	3.1	40.1	9.6	115	240
PVM64-1	15	1.15	3	208-230V/460V	254TC	24.5	20.0	12.9	3.8	48.3	12.9	151	426	24.5	20.0	12.9	3.8	48.3	12.9	136	411
PVM64-2-2	20	1.15	3	230V/460V	254TC	27.8	16.9	10.3	3.8	48.4	10.3	160	385	27.8	16.9	10.3	3.8	48.4	10.3	145	370
PVM64-2-1	20	1.15	3	230V/460V	254TC	27.8	16.9	10.3	3.8	48.4	10.3	160	385	27.8	16.9	10.3	3.8	48.4	10.3	145	370
PVM64-2	25	1.15	3	230V/460V	284TSC	29.8	20.0	12.9	3.0	52.8	12.9	162	483	29.8	20.0	12.9	3.0	52.8	12.9	147	468
PVM64-3-2	30	1.15	3	230V/460V	284TSC	33.0	23.2	15.6	3.0	59.2	15.6	172	595	33.0	23.2	15.6	3.0	59.2	15.6	156	579
PVM64-3-1	40	1.15	3	230V/460V	286TSC	33.0	23.2	15.6	3.0	59.2	15.6	172	652	33.0	23.2	15.6	3.0	59.2	15.6	156	636
PVM64-3	40	1.15	3	230V/460V	286TSC	33.0	23.2	15.6	3.0	59.2	15.6	172	652	33.0	23.2	15.6	3.0	59.2	15.6	156	636
PVM64-4-2	40	1.15	3	230V/460V	286TSC	36.3	23.2	15.6	3.0	62.5	15.6	180	660	36.3	23.2	15.6	3.0	62.5	15.6	156	636
PVM64-4-1	50	1.15	3 (TEFC)	230V/460V	326TSC	36.3	28.8	16.5	3.5	68.6	16.5	198	698	36.3	28.8	16.5	3.5	68.6	16.5	182	682
PVM64-4-1	50	1.15	3 (ODP)	230V/460V	324TSC	36.3	25.7	16.5	3.5	65.5	16.5	198	577	36.3	25.7	16.5	3.5	65.5	16.5	182	561
PVM64-4	50	1.15	3 (TEFC)	230V/460V	326TSC	36.4	28.8	16.5	3.5	68.7	16.5	198	698	36.4	28.8	16.5	3.5	68.7	16.5	182	682
PVM64-4	50	1.15	3 (ODP)	230V/460V	324TSC	36.4	25.7	16.5	3.5	65.6	16.5	198	577	36.4	25.7	16.5	3.5	65.6	16.5	182	561
PVM64-5-2	60	1.15	3 (TEFC)	230V/460V	364TSC	39.6	31.4	18.5	3.5	74.5	18.5	206	890	39.6	31.4	18.5	3.5	74.5	18.5	182	866
PVM64-5-2	60	1.15	3 (ODP)	230V/460V	324TSC	39.6	25.7	18.5	3.5	68.8	18.5	206	595	39.6	25.7	18.5	3.5	68.8	18.5	182	571

### PVM

### PVMX

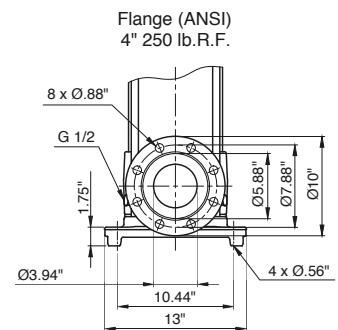
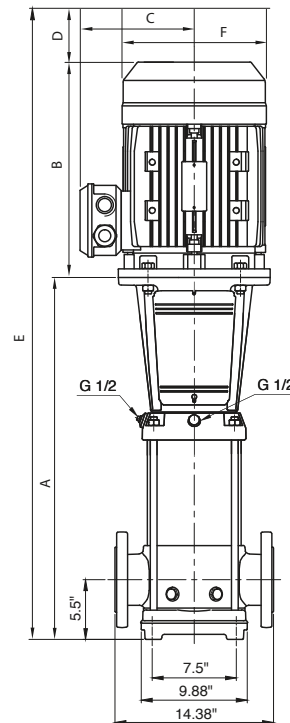
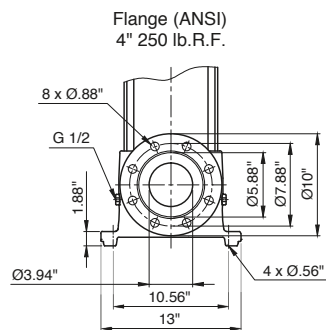
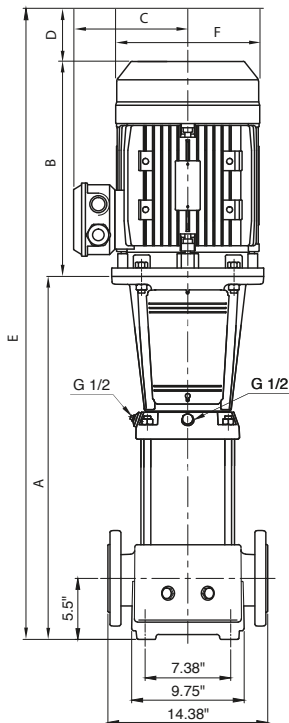

NOTE: G1/2 per ISO-228

# PVM(X) 64

## VERTICAL MULTISTAGE CENTRIFUGAL PUMPS

### PUMP DIMENSIONS - METRIC

Model Number	Motor HP	Motor Safety Factor	Phase	Voltage	Motor Frame	PVM Cast Iron							PVMX Stainless Steel								
						Dimensions in mm						Weight in kgs		Dimensions in mm						Weight in kgs	
						A	B	C	D	E	F	Pump End Only	Pump & Motor	A	B	C	D	E	F	Pump End Only	Pump & Motor
PVM64-1-1	10	1.15	1	208-230V	215TC	544	422	243	79	1045	243	59	120	544	422	243	79	1045	243	52	113
PVM64-1-1	10	1.15	3	208-230V/460V	215TC	544	394	243	79	1017	243	59	116	544	394	243	79	1017	243	52	109
PVM64-1	15	1.15	3	208-230V/460V	254TC	622	509	329	95	1226	329	68	193	622	509	329	95	1226	329	62	186
PVM64-2-2	20	1.15	3	230V/460V	254TC	706	428	263	95	1230	263	73	175	706	428	263	95	1230	263	66	168
PVM64-2-1	20	1.15	3	230V/460V	254TC	706	428	263	95	1230	263	73	175	706	428	263	95	1230	263	66	168
PVM64-2	25	1.15	3	230V/460V	284TSC	757	507	329	76	1340	329	73	219	757	507	329	76	1340	329	67	212
PVM64-3-2	30	1.15	3	230V/460V	284TSC	838	589	395	76	1503	395	78	270	838	589	395	76	1503	395	71	263
PVM64-3-1	40	1.15	3	230V/460V	286TSC	838	589	395	76	1503	395	78	296	838	589	395	76	1503	395	71	288
PVM64-3	40	1.15	3	230V/460V	286TSC	838	589	395	76	1503	395	78	296	838	589	395	76	1503	395	71	288
PVM64-4-2	40	1.15	3	230V/460V	286TSC	922	589	395	76	1587	395	82	299	922	589	395	76	1587	395	71	288
PVM64-4-1	50	1.15	3 (TEFC)	230V/460V	326TSC	922	731	419	89	1742	419	90	317	922	731	419	89	1742	419	83	309
PVM64-4-1	50	1.15	3 (ODP)	230V/460V	324TSC	922	653	419	89	1663	419	90	262	922	653	419	89	1663	419	83	254
PVM64-4	50	1.15	3 (TEFC)	230V/460V	326TSC	925	731	419	89	1744	419	90	317	925	731	419	89	1744	419	83	309
PVM64-4	50	1.15	3 (ODP)	230V/460V	324TSC	925	653	419	89	1666	419	90	262	925	653	419	89	1666	419	83	254
PVM64-5-2	60	1.15	3 (TEFC)	230V/460V	364TSC	1006	797	470	89	1891	470	93	404	1006	797	470	89	1891	470	83	393
PVM64-5-2	60	1.15	3 (ODP)	230V/460V	324TSC	1006	653	470	89	1747	470	93	270	1006	653	470	89	1747	470	83	259

PVM

PVMX

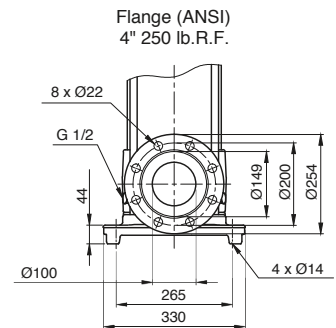
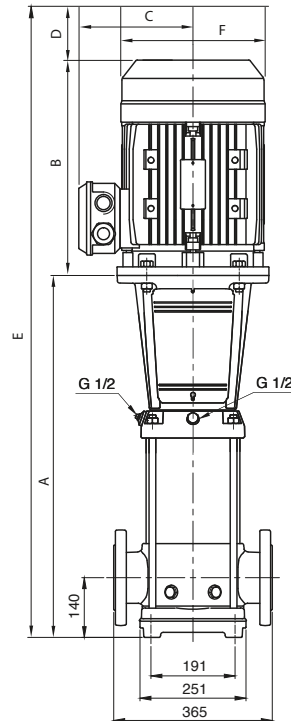
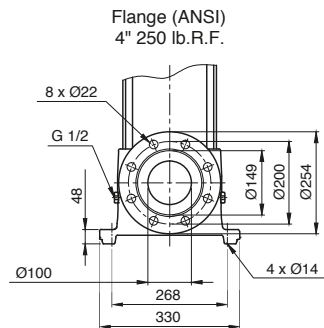
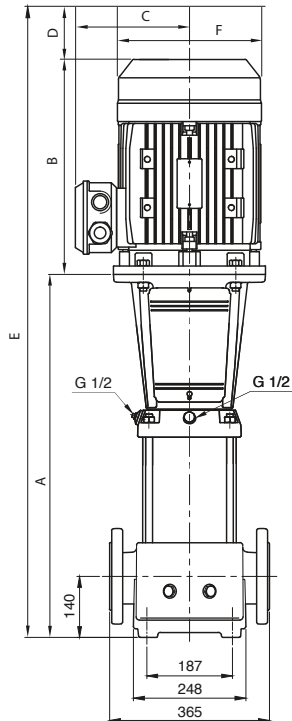

NOTE: G1/2 per ISO-228

# PVM(X) 64

## VERTICAL MULTISTAGE CENTRIFUGAL PUMPS

### HYDRAULIC PERFORMANCE

Curve PVM(X) 64  
Date 10/01/14

Nominal rpm: 3500  
Based on fresh water @ 68° F  
Maximum working pressure: 435 psi

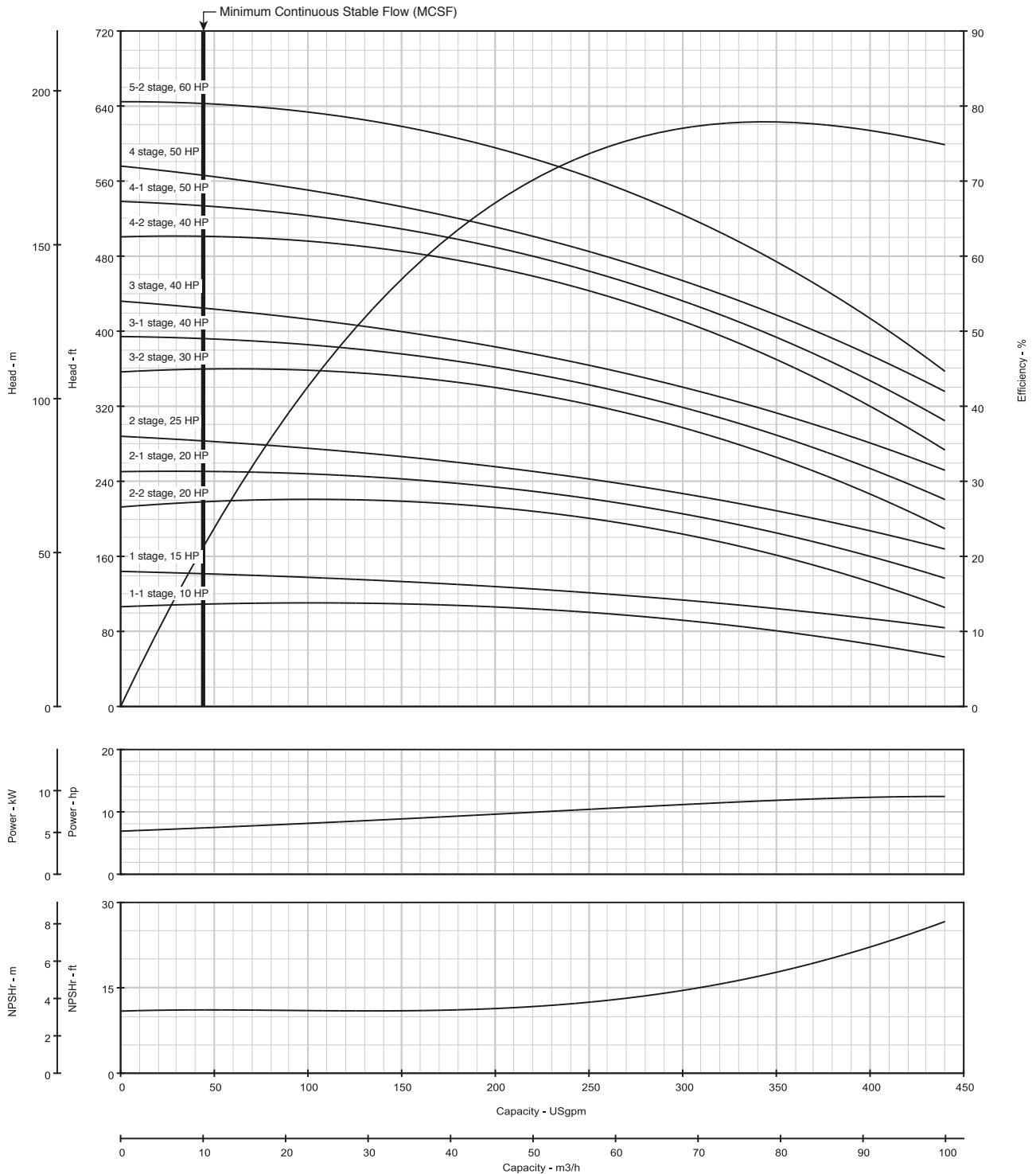

# PVM(X) 90

## VERTICAL MULTISTAGE CENTRIFUGAL PUMPS

### PUMP DIMENSIONS – STANDARD

Model Number	Motor HP	Motor Service Factor	Phase	Voltage	Motor Frame	PVM Cast Iron								PVMX Stainless Steel							
						Dimensions in inches						Weight in Lbs		Dimensions in inches						Weight in Lbs	
						A	B	C	D	E	F	Pump End Only	Pump & Motor	A	B	C	D	E	F	Pump End Only	Pump & Motor
PVM90-1-1	15	1.15	3	208-230V/460V	254TC	24.9	20.0	12.9	3.8	48.7	12.9	181	456	25.0	20.0	12.9	3.8	48.8	12.9	159	434
PVM90-1	20	1.15	3	230V/460V	254TC	24.9	16.9	10.3	3.8	45.5	10.3	181	406	25.0	16.9	10.3	3.8	45.6	10.3	159	384
PVM90-2-2	25	1.15	3	230V/460V	284TSC	30.5	20.0	12.9	3.0	53.5	12.9	194	515	30.6	20.0	12.9	3.0	53.6	12.9	172	493
PVM90-2-1	30	1.15	3	230V/460V	284TSC	30.5	23.2	15.6	3.0	56.7	15.6	194	617	30.6	23.2	15.6	3.0	56.8	15.6	172	595
PVM90-2	40	1.15	3	230V/460V	286TSC	30.5	23.2	15.6	3.0	56.7	15.6	194	674	30.6	23.2	15.6	3.0	56.8	15.6	172	652
PVM90-3-2	40	1.15	3	230V/460V	286TSC	34.1	23.2	15.6	3.0	60.3	15.6	205	685	34.3	23.2	15.6	3.0	60.5	15.6	184	664
PVM90-3-1	50	1.15	3 (TEFC)	230V/460V	326TSC	34.1	28.8	16.5	3.5	66.4	16.5	223	723	34.3	28.8	16.5	3.5	66.6	16.5	201	701
PVM90-3-1	50	1.15	3 (ODP)	230V/460V	324TSC	34.1	25.7	16.5	3.5	63.3	16.5	223	602	34.3	25.7	16.5	3.5	63.5	16.5	201	580
PVM90-3	50	1.15	3 (TEFC)	230V/460V	326TSC	34.1	28.8	16.5	3.5	66.4	16.5	223	723	34.3	28.8	16.5	3.5	66.6	16.5	201	701
PVM90-3	50	1.15	3 (ODP)	230V/460V	324TSC	34.1	25.7	16.5	3.5	63.3	16.5	223	602	34.3	25.7	16.5	3.5	63.5	16.5	201	580
PVM90-4-2	60	1.15	3 (TEFC)	230V/460V	364TSC	37.7	31.4	18.5	3.5	72.6	18.5	238	922	37.9	31.4	18.5	3.5	72.8	18.5	216	900
PVM90-4-2	60	1.15	3 (ODP)	230V/460V	324TSC	37.7	25.7	18.5	3.5	66.9	18.5	238	627	37.9	25.7	18.5	3.5	67.1	18.5	216	605
PVM90-4-1	60	1.15	3 (TEFC)	230V/460V	364TSC	37.7	31.4	18.5	3.5	72.6	18.5	238	922	40.9	31.4	18.5	3.5	75.8	18.5	216	900
PVM90-4-1	60	1.15	3 (ODP)	230V/460V	324TSC	37.7	25.7	18.5	3.5	66.9	18.5	238	627	40.9	25.7	18.5	3.5	70.1	18.5	216	605

**PVM**

**PVMX**

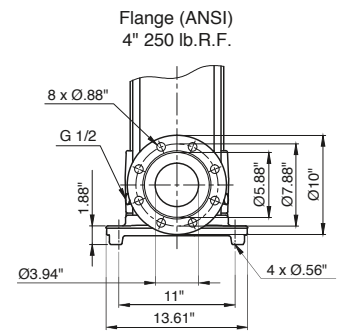
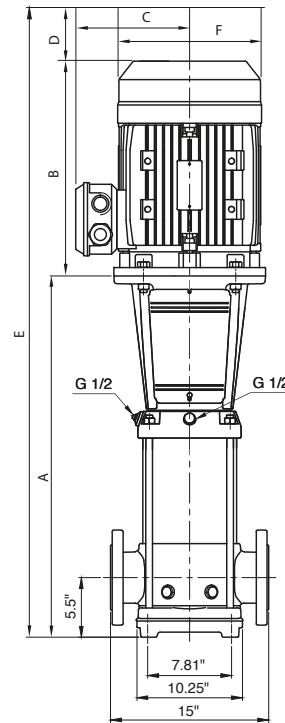
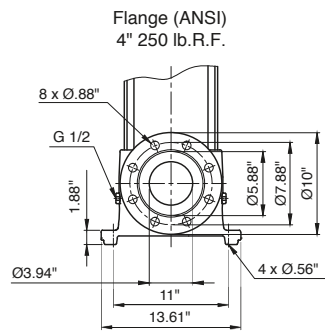
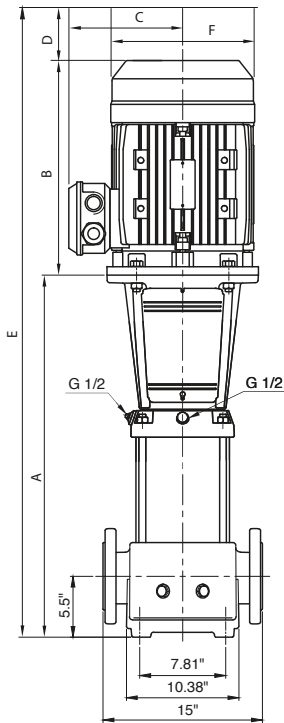

NOTE: G1/2 per ISO-228

# PVM(X) 90

## VERTICAL MULTISTAGE CENTRIFUGAL PUMPS

### PUMP DIMENSIONS - METRIC

Model Number	Motor HP	Motor Service Factor	Phase	Voltage	Motor Frame	PVM Cast Iron								PVMX Stainless Steel							
						Dimensions in mm						Weight in kgs		Dimensions in mm						Weight in kgs	
						A	B	C	D	E	F	Pump End Only	Pump & Motor	A	B	C	D	E	F	Pump End Only	Pump & Motor
PVM90-1-1	15	1.15	3	208-230V/460V	254TC	632	509	329	95	1236	329	82	207	635	509	329	95	1239	329	72	197
PVM90-1	20	1.15	3	230V/460V	254TC	632	428	263	95	1156	263	82	184	635	428	263	95	1158	263	72	174
PVM90-2-2	25	1.15	3	230V/460V	284TSC	775	507	329	76	1358	329	88	234	777	507	329	76	1361	329	78	224
PVM90-2-1	30	1.15	3	230V/460V	284TSC	775	589	395	76	1440	395	88	280	777	589	395	76	1442	395	78	270
PVM90-2	40	1.15	3	230V/460V	286TSC	775	589	395	76	1440	395	88	306	777	589	395	76	1442	395	78	296
PVM90-3-2	40	1.15	3	230V/460V	286TSC	866	589	395	76	1531	395	93	311	871	589	395	76	1536	395	83	301
PVM90-3-1	50	1.15	3 (TEFC)	230V/460V	326TSC	866	731	419	89	1686	419	101	328	871	731	419	89	1691	419	91	318
PVM90-3-1	50	1.15	3 (ODP)	230V/460V	324TSC	866	653	419	89	1608	419	101	273	871	653	419	89	1613	419	91	263
PVM90-3	50	1.15	3 (TEFC)	230V/460V	326TSC	866	731	419	89	1686	419	101	328	871	731	419	89	1691	419	91	318
PVM90-3	50	1.15	3 (ODP)	230V/460V	324TSC	866	653	419	89	1608	419	101	273	871	653	419	89	1613	419	91	263
PVM90-4-2	60	1.15	3 (TEFC)	230V/460V	364TSC	958	797	470	89	1843	470	108	418	963	797	470	89	1848	470	98	408
PVM90-4-2	60	1.15	3 (ODP)	230V/460V	324TSC	958	653	470	89	1699	470	108	284	963	653	470	89	1704	470	98	274
PVM90-4-1	60	1.15	3 (TEFC)	230V/460V	364TSC	958	797	470	89	1843	470	108	418	1039	797	470	89	1924	470	98	408
PVM90-4-1	60	1.15	3 (ODP)	230V/460V	324TSC	958	653	470	89	1699	470	108	284	1039	653	470	89	1780	470	98	274

**PVM**

**PVMX**

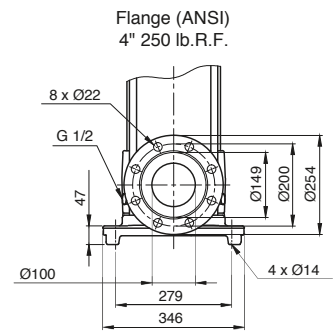
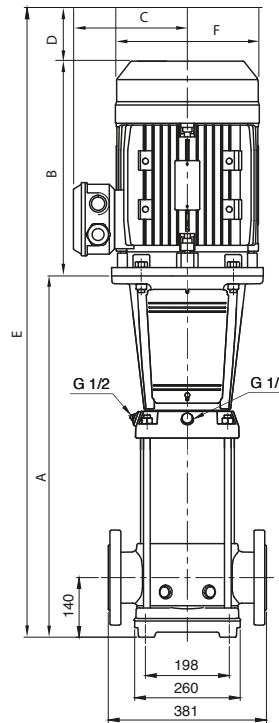
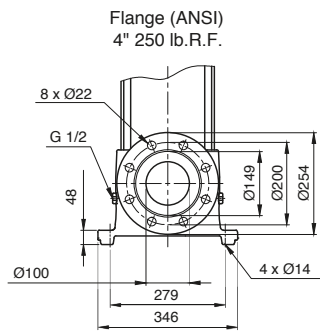
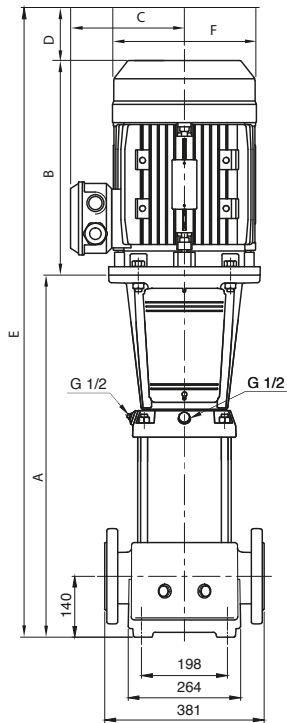

NOTE: G1/2 per ISO-228

# PVM(X) 90

## VERTICAL MULTISTAGE CENTRIFUGAL PUMPS

### HYDRAULIC PERFORMANCE

Curve PVM(X) 90  
Date 10/01/14

Nominal rpm: 3500  
Based on fresh water @ 68° F  
Maximum working pressure: 435 psi

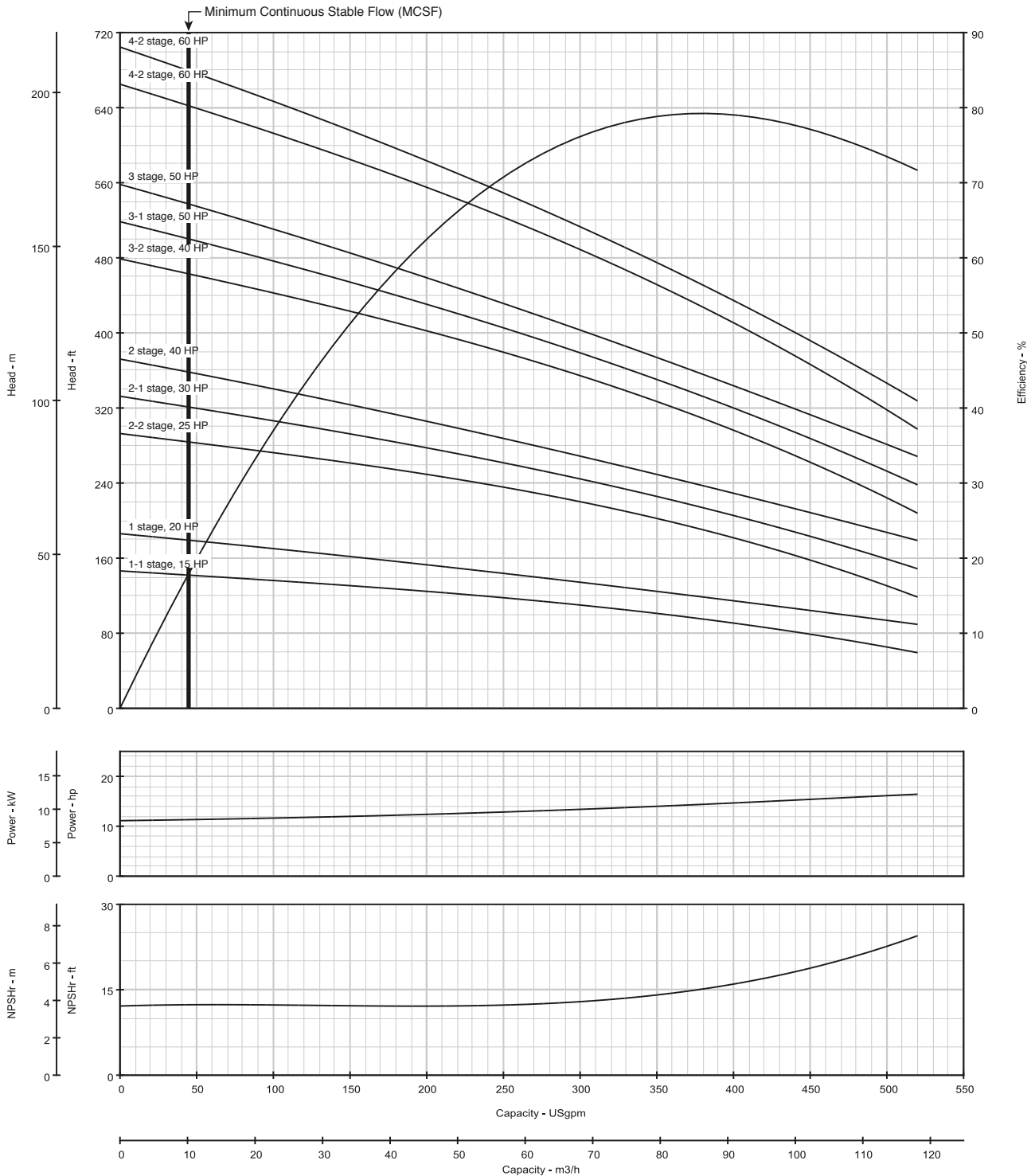

# PVM(X) 120

## VERTICAL MULTISTAGE CENTRIFUGAL PUMPS

### PUMP DIMENSIONS - STANDARD

Model Number	Motor HP	Motor Service Factor	Phase	Voltage	Motor Frame	PVM Cast Iron								PVMX Stainless Steel							
						Dimensions in inches						Weight in Lbs		Dimensions in inches						Weight in Lbs	
						A	B	C	D	E	F	Pump End Only	Pump & Motor	A	B	C	D	E	F	Pump End Only	Pump & Motor
PVM120-1-1	20	1.15	3	230V/460V	254TC	32.8	20.0	12.9	3.8	56.5	12.9	247	568	33.0	20.0	12.9	3.8	56.7	12.9	204	525
PVM120-1	25	1.15	3	230V/460V	284TSC	32.8	20.0	12.9	3.0	55.8	12.9	247	568	33.0	20.0	12.9	3.0	56.0	12.9	204	525
PVM120-2-2	40	1.15	3	230V/460V	286TSC	39.0	23.2	15.6	3.0	65.2	15.6	249	729	39.1	23.2	15.6	3.0	65.3	15.6	237	717
PVM120-2-1	40	1.15	3	230V/460V	286TSC	39.0	23.2	15.6	3.0	65.2	15.6	270	750	39.1	23.2	15.6	3.0	65.3	15.6	237	717
PVM120-2	50	1.15	3 (TEFC)	230V/460V	326TSC	39.0	28.8	16.5	3.5	71.3	16.5	288	788	39.1	28.8	16.5	3.5	71.4	16.5	255	755
PVM120-2	50	1.15	3 (ODP)	230V/460V	324TSC	39.0	25.7	16.5	3.5	68.2	16.5	288	667	39.1	25.7	16.5	3.5	68.3	16.5	255	634
PVM120-3-1	60	1.15	3 (TEFC)	230V/460V	364TSC	45.2	31.4	18.5	3.5	80.1	18.5	309	993	45.4	31.4	18.5	3.5	80.3	18.5	276	960
PVM120-3-1	60	1.15	3 (ODP)	230V/460V	324TSC	45.2	25.7	18.5	3.5	74.4	18.5	309	698	45.4	25.7	18.5	3.5	74.6	18.5	276	665
PVM120-3	75	1.15	3 (TEFC)	230V/460V	365TSC	46.3	31.4	18.5	3.5	81.2	18.5	364	1202	46.4	31.4	18.5	3.5	81.3	18.5	331	1169
PVM120-3	75	1.15	3 (ODP)	230V/460V	364TSC	46.3	25.8	18.5	3.5	75.6	18.5	364	836	46.4	25.8	18.5	3.5	75.7	18.5	331	803
PVM120-4-1	100	1.15	3 (TEFC)	230V/460V	405TSC	52.4	35.0	21.3	4.0	91.4	21.3	385	1442	52.5	35.0	21.3	4.0	91.5	21.3	353	1410
PVM120-4-1	100	1.15	3 (ODP)	230V/460V	365TSC	52.4	27.8	21.3	3.5	83.7	21.3	385	908	52.5	27.8	21.3	3.5	83.8	21.3	353	876
PVM120-5-2	100	1.15	3 (TEFC)	230V/460V	405TSC	58.5	35.0	21.3	4.0	97.5	21.3	407	1464	58.6	35.0	21.3	4.0	97.6	21.3	374	1431

PVM

PVMX

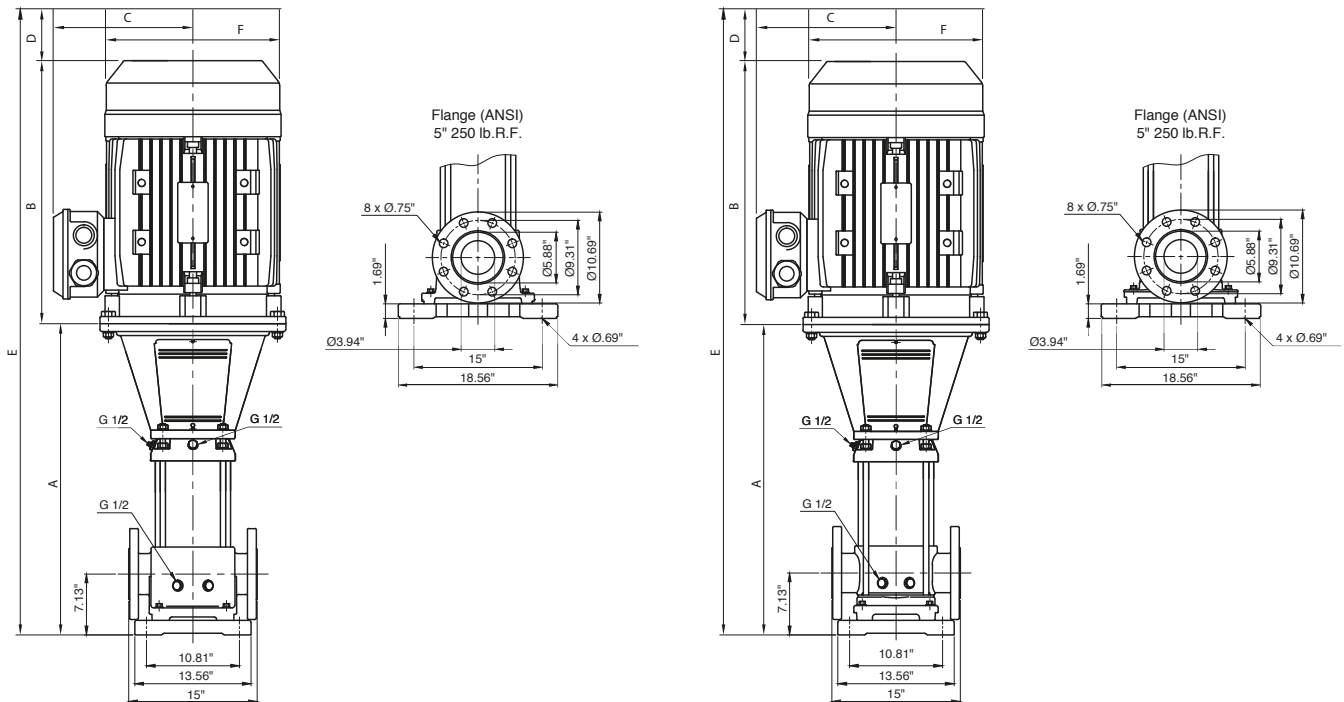

NOTE: G1/2 per ISO-228

# PVM(X) 120

## VERTICAL MULTISTAGE CENTRIFUGAL PUMPS

### PUMP DIMENSIONS - METRIC

Model Number	Motor HP	Motor Service Factor	Phase	Voltage	Motor Frame	PVM Cast Iron							PVMX Stainless Steel								
						Dimensions in mm						Weight in kgs		Dimensions in mm						Weight in kgs	
						A	B	C	D	E	F	Pump End Only	Pump & Motor	A	B	C	D	E	F	Pump End Only	Pump & Motor
PVM120-1-1	20	1.15	3	230V/460V	254TC	833	507	329	95	1436	329	112	258	838	507	329	95	1441	329	93	238
PVM120-1	25	1.15	3	230V/460V	284TSC	833	507	329	76	1417	329	112	258	838	507	329	76	1422	329	93	238
PVM120-2-2	40	1.15	3	230V/460V	286TSC	991	589	395	76	1656	395	113	331	993	589	395	76	1658	395	107	325
PVM120-2-1	40	1.15	3	230V/460V	286TSC	991	589	395	76	1656	395	122	340	993	589	395	76	1658	395	107	325
PVM120-2	50	1.15	3 (TEFC)	230V/460V	326TSC	991	731	419	89	1811	419	131	357	993	731	419	89	1813	419	116	342
PVM120-2	50	1.15	3 (ODP)	230V/460V	324TSC	991	653	419	89	1732	419	131	302	993	653	419	89	1735	419	116	288
PVM120-3-1	60	1.15	3 (TEFC)	230V/460V	364TSC	1148	797	470	89	2034	470	140	450	1153	797	470	89	2039	470	125	435
PVM120-3-1	60	1.15	3 (ODP)	230V/460V	324TSC	1148	653	470	89	1890	470	140	317	1153	653	470	89	1895	470	125	302
PVM120-3	75	1.15	3 (TEFC)	230V/460V	365TSC	1176	797	470	89	2061	470	165	545	1179	797	470	89	2064	470	150	530
PVM120-3	75	1.15	3 (ODP)	230V/460V	364TSC	1176	656	470	89	1920	470	165	379	1179	656	470	89	1923	470	150	364
PVM120-4-1	100	1.15	3 (TEFC)	230V/460V	405TSC	1331	890	541	102	2323	541	175	654	1334	890	541	102	2325	541	160	639
PVM120-4-1	100	1.15	3 (ODP)	230V/460V	365TSC	1331	706	541	89	2126	541	175	412	1334	706	541	89	2129	541	160	397
PVM120-5-2	100	1.15	3 (TEFC)	230V/460V	405TSC	1486	890	541	102	2478	541	185	664	1488	890	541	102	2480	541	170	649

### PVM

### PVMX

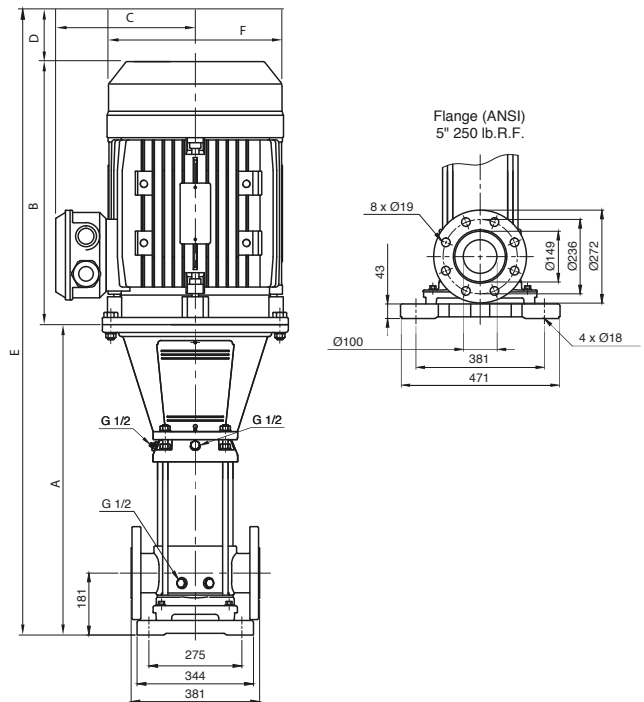
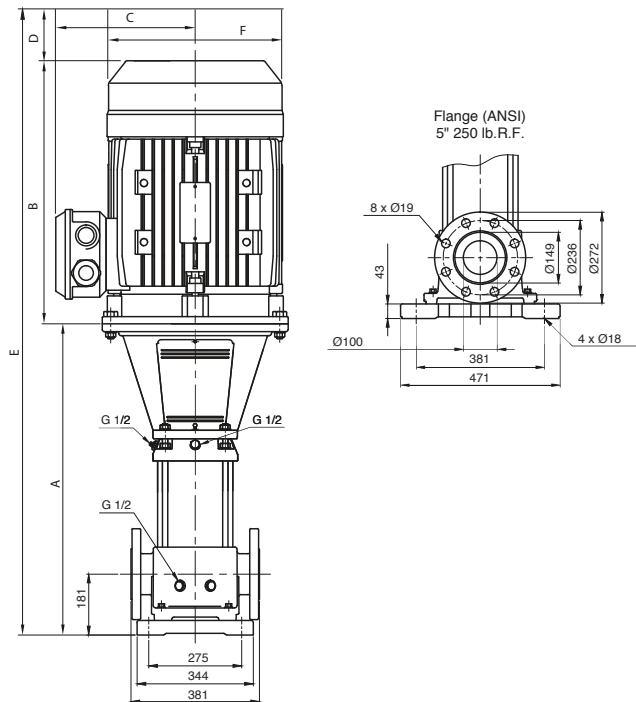

NOTE: G1/2 per ISO-228

# PVM(X) 120

## VERTICAL MULTISTAGE CENTRIFUGAL PUMPS

### HYDRAULIC PERFORMANCE

Curve PVM(X) 120  
Date 10/01/14

Nominal rpm: 3500  
Based on fresh water @ 68° F  
Maximum working pressure: 435 psi

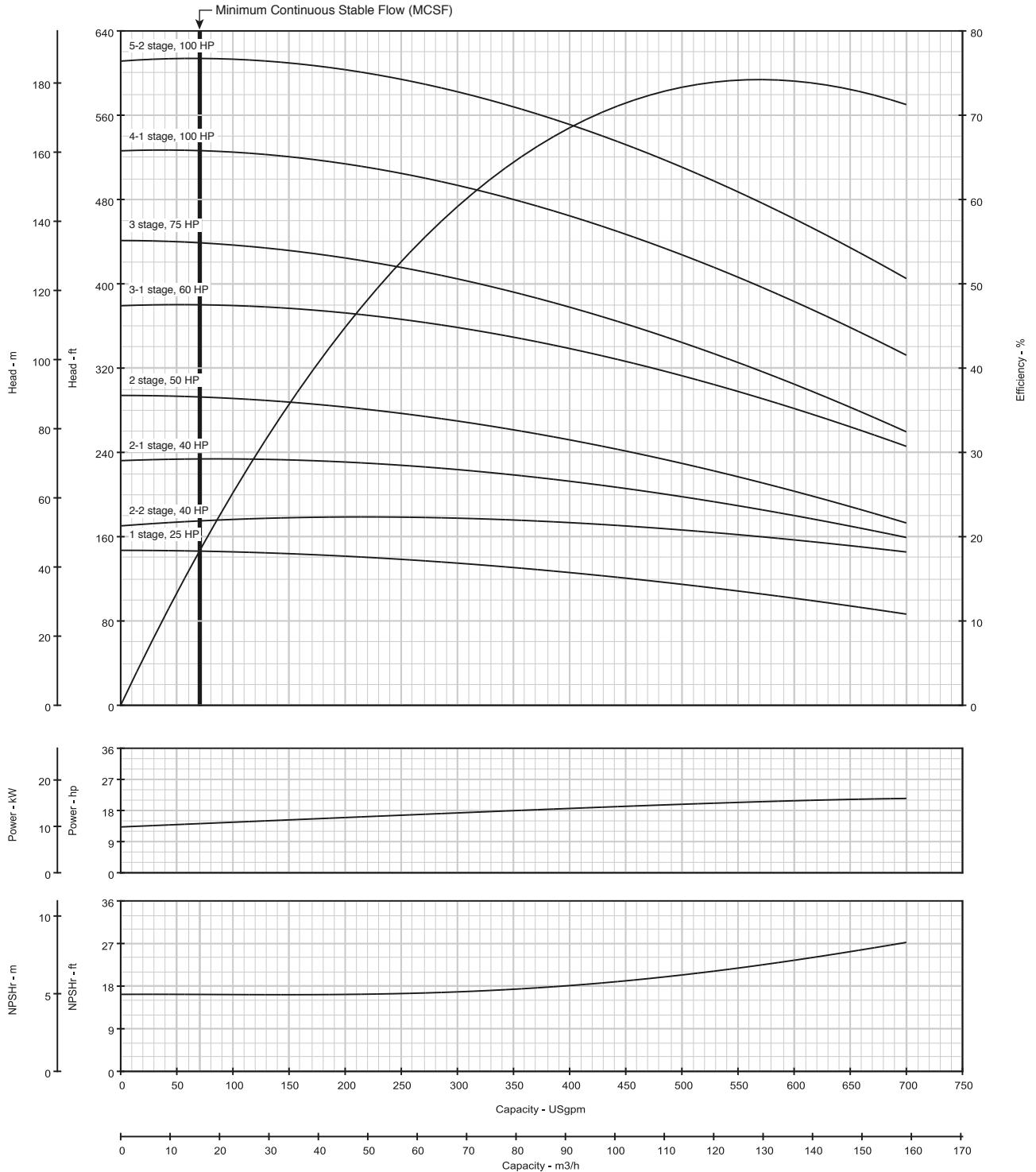

# PVM(X) 150

## VERTICAL MULTISTAGE CENTRIFUGAL PUMPS

### PUMP DIMENSIONS – STANDARD

Model Number	Motor HP	Motor Service Factor	Phase	Voltage	Motor Frame	PVM Cast Iron							PVMX Stainless Steel								
						Dimensions in inches						Weight in Lbs		Dimensions in inches						Weight in Lbs	
						A	B	C	D	E	F	Pump End Only	Pump & Motor	A	B	C	D	E	F	Pump End Only	Pump & Motor
PVM150-1-1	25	1.15	3	230V/460V	284TSC	32.8	20.0	12.9	3.0	55.8	12.9	249	570	33.0	20.0	12.9	3.0	56.0	12.9	214	535
PVM150-1	30	1.15	3	230V/460V	284TSC	32.8	23.2	15.6	3.0	59.0	15.6	249	672	33.0	23.2	15.6	3.0	59.2	15.6	214	637
PVM150-2-2	40	1.15	3	230V/460V	286TSC	39.0	23.2	15.6	3.0	65.2	15.6	270	750	39.1	23.2	15.6	3.0	65.3	15.6	236	716
PVM150-2-1	50	1.15	3 (TEFC)	230V/460V	326TSC	39.0	28.8	16.5	3.5	71.3	16.5	270	770	39.1	28.8	16.5	3.5	71.4	16.5	236	736
PVM150-2-1	50	1.15	3 (ODP)	230V/460V	324TSC	39.0	25.7	16.5	3.5	68.2	16.5	270	649	39.1	25.7	16.5	3.5	68.3	16.5	236	615
PVM150-2	60	1.15	3 (TEFC)	230V/460V	364TSC	39.1	31.4	18.5	3.5	74.0	18.5	288	972	39.3	31.4	18.5	3.5	74.2	18.5	253	937
PVM150-2	60	1.15	3 (ODP)	230V/460V	324TSC	39.1	25.7	18.5	3.5	68.3	18.5	288	677	39.3	25.7	18.5	3.5	68.5	18.5	253	642
PVM150-3-2	75	1.15	3 (TEFC)	230V/460V	365TSC	46.3	31.4	18.5	3.5	81.2	18.5	364	1202	46.4	31.4	18.5	3.5	81.3	18.5	329	1167
PVM150-3-2	75	1.15	3 (ODP)	230V/460V	364TSC	46.3	25.8	18.5	3.5	75.6	18.5	364	836	46.4	25.8	18.5	3.5	75.7	18.5	329	801
PVM150-3	100	1.15	3 (TEFC)	230V/460V	405TSC	46.3	35.0	21.3	4.0	85.3	21.3	364	1421	46.4	35.0	21.3	4.0	85.4	21.3	329	1386
PVM150-3	100	1.15	3 (ODP)	230V/460V	365TSC	46.3	27.8	21.3	3.5	77.6	21.3	364	887	46.4	27.8	21.3	3.5	77.7	21.3	329	852
PVM150-4-2	100	1.15	3 (TEFC)	230V/460V	405TSC	52.4	35.0	21.3	4.0	91.4	21.3	385	1442	52.5	35.0	21.3	4.0	91.5	21.3	349	1406
PVM150-4-2	100	1.15	3 (ODP)	230V/460V	365TSC	52.4	27.8	21.3	3.5	83.7	21.3	385	908	52.5	27.8	21.3	3.5	83.8	21.3	349	872

### PVM

### PVMX

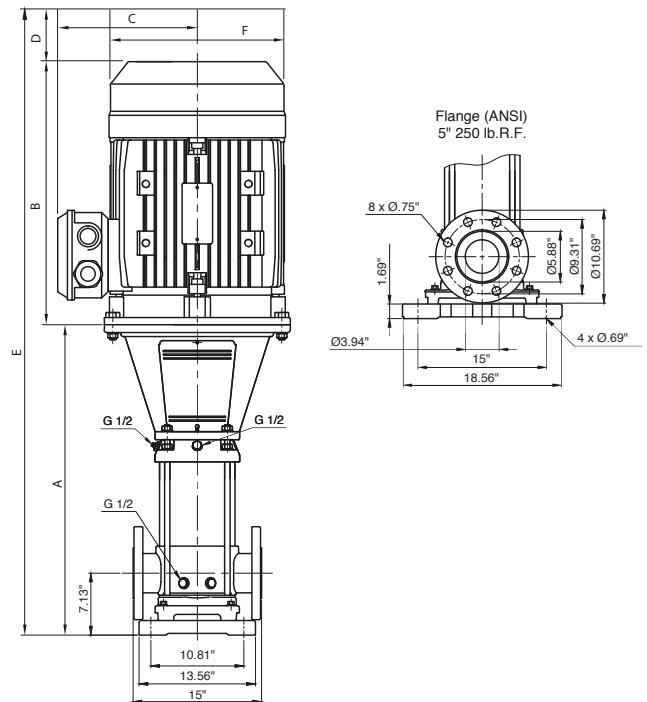
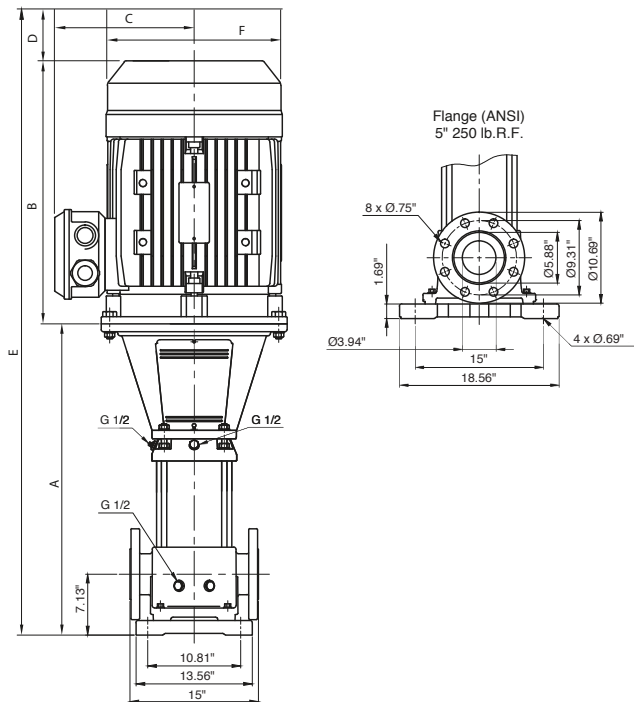

NOTE: G1/2 per ISO-228

# PVM(X) 150

## VERTICAL MULTISTAGE CENTRIFUGAL PUMPS

### PUMP DIMENSIONS - METRIC

Model Number	Motor HP	Motor Service Factor	Phase	Voltage	Motor Frame	PVM Cast Iron								PVMX Stainless Steel							
						Dimensions in mm						Weight in kgs		Dimensions in mm						Weight in kgs	
						A	B	C	D	E	F	Pump End Only	Pump & Motor	A	B	C	D	E	F	Pump End Only	Pump & Motor
PVM150-1-1	25	1.15	3	230V/460V	284TSC	833	507	329	76	1417	329	113	259	838	507	329	76	1422	329	97	243
PVM150-1	30	1.15	3	230V/460V	284TSC	833	589	395	76	1498	395	113	305	838	589	395	76	1503	395	97	289
PVM150-2-2	40	1.15	3	230V/460V	286TSC	991	589	395	76	1656	395	122	340	993	589	395	76	1658	395	107	325
PVM150-2-1	50	1.15	3 (TEFC)	230V/460V	326TSC	991	731	419	89	1811	419	122	349	993	731	419	89	1813	419	107	334
PVM150-2-1	50	1.15	3 (ODP)	230V/460V	324TSC	991	653	419	89	1732	419	122	294	993	653	419	89	1735	419	107	279
PVM150-2	60	1.15	3 (TEFC)	230V/460V	364TSC	993	797	470	89	1879	470	131	441	998	797	470	89	1884	470	115	425
PVM150-2	60	1.15	3 (ODP)	230V/460V	324TSC	993	653	470	89	1735	470	131	307	998	653	470	89	1740	470	115	291
PVM150-3-2	75	1.15	3 (TEFC)	230V/460V	365TSC	1176	797	470	89	2061	470	165	545	1179	797	470	89	2064	470	149	529
PVM150-3-2	75	1.15	3 (ODP)	230V/460V	364TSC	1176	656	470	89	1920	470	165	379	1179	656	470	89	1923	470	149	363
PVM150-3	100	1.15	3 (TEFC)	230V/460V	405TSC	1176	890	541	102	2168	541	165	644	1179	890	541	102	2170	541	149	629
PVM150-3	100	1.15	3 (ODP)	230V/460V	365TSC	1176	706	541	89	1971	541	165	402	1179	706	541	89	1974	541	149	386
PVM150-4-2	100	1.15	3 (TEFC)	230V/460V	405TSC	1331	890	541	102	2323	541	175	654	1334	890	541	102	2325	541	158	638
PVM150-4-2	100	1.15	3 (ODP)	230V/460V	365TSC	1331	706	541	89	2126	541	175	412	1334	706	541	89	2129	541	158	395

### PVM

### PVMX

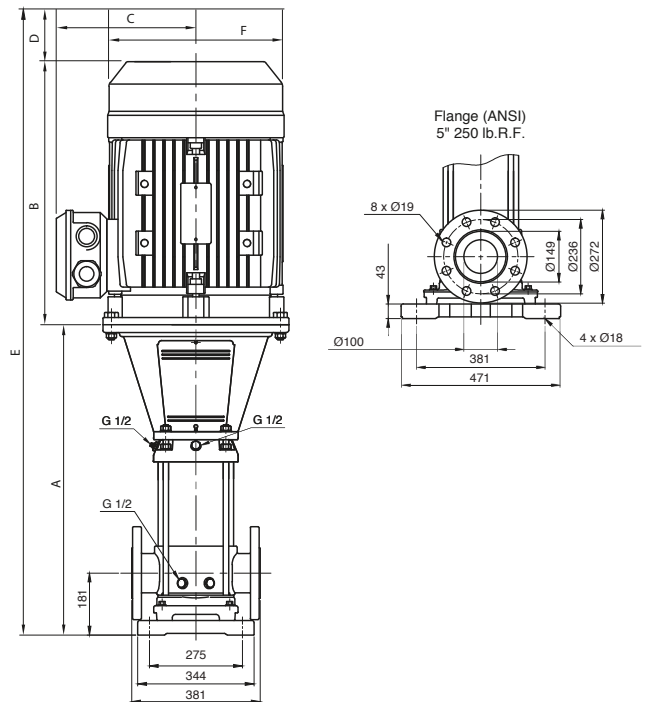
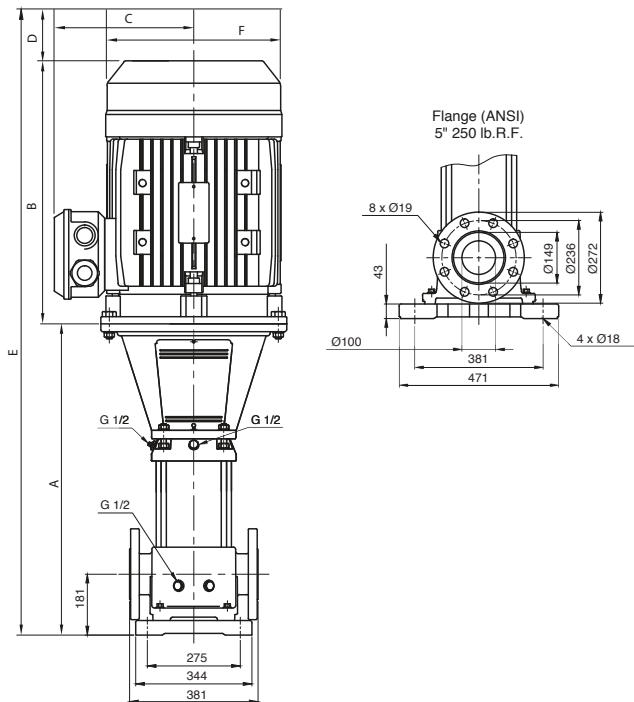

NOTE: G1/2 per ISO-228

# PVM(X) 150

## VERTICAL MULTISTAGE CENTRIFUGAL PUMPS

### HYDRAULIC PERFORMANCE

Curve PVM(X) 150  
Date 10/01/14

Nominal rpm: 3500  
Based on fresh water @ 68°F  
Maximum working pressure: 435 psi

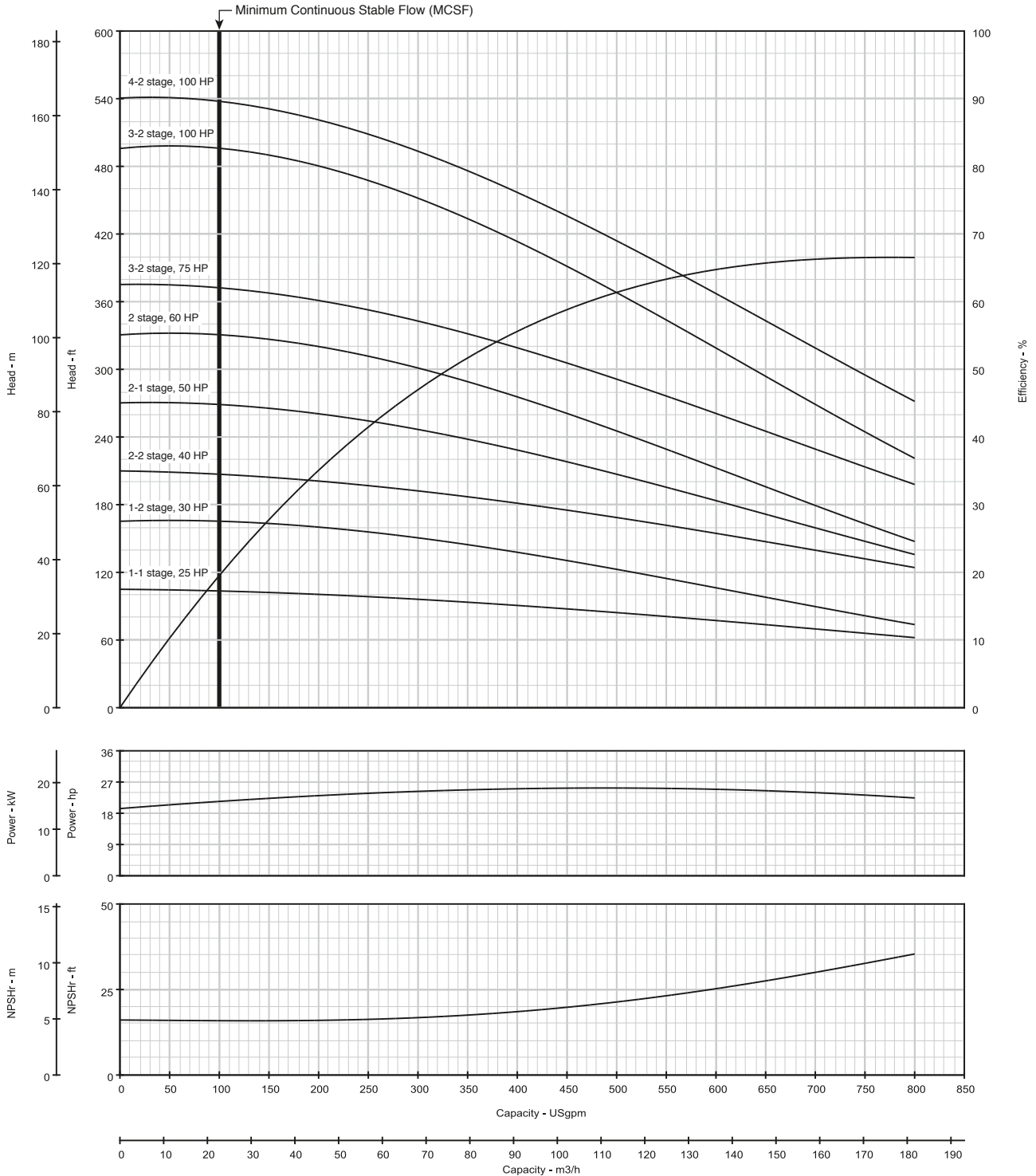



# WATER ENERGY

## WE PUT ENERGY INTO YOUR WATER

Pentair has been committed to the design and production of electric water pumps providing our customers with quality products and concrete solutions for all their needs. Within the wide Pentair supply range, engineering firms and plumbing and heating/cooling distributing centres can find products and systems which meet any need with regards to water supply and pressurization in the realm of residential and commercial building, irrigation and industry applications.



### **FIRE-FIGHTING SYSTEMS AND PRESSURIZATION SYSTEMS**

Vertical and horizontal centrifugal pumps. Complete systems for the transfer and pressurization of water. Fire-fighting systems.



### **ELECTRIC PUMPS FOR RESIDENTIAL USE**

Submersible pumps, self-priming pumps, multistage centrifugal pumps and compacting pumping systems for domestic water supply, irrigation and the re-utilization of harvested rainwater.



### **ELECTRIC PUMPS FOR DRAINAGE**

Pumps for the transfer of clear, dirty and wastewaters and sewage. Pumps for numerous applications (water in basins, tanks, pumping stations etc.)



### **ELECTRIC PUMPS FOR OPEN AND DRILLED WELLS**

Submersible pumps for irrigation and pumping underground waters.



800 AIRPORT ROAD, NORTH AURORA, ILLINOIS • PH: 630-859-7000 • [www.AuroraPump.com](http://www.AuroraPump.com)

Because we are continuously improving our products and services, Pentair reserves the right to change specifications without prior notice.

© 2015 Pentair Ltd. All Rights Reserved.

A-02-1078 (11/10/15)